



Odisha Power Generation Corporation Limited

IB Thermal Power Station

At/P.O: Banharpali, Dist. Jharsuguda, PIN: 768234(Odisha)

GRAM: IB THERMAL, Tel.06645-289354/5/6; Tele Fax: 06645- 289355
Email: bhadoo.jojowar@opgc.co.in; bhujanga.pati@opgc.co.in; bn.das@opgc.co.in;

SAFE & CLEAN POWER IS OUR COMMITMENT

AN ISO-14001; OHSAS-18001 ORGANISATION

Tender Information	
Classification	Supply of High Chrome Mill Liner to IB Thermal Power Station.
NIT Number	ITPS (Purchase)/20116-17/11(P) Dt. 20-10-2016
Brief NIT Description	Manufacturer & Ssupply of Hi Chrome Mill Liner For BBD 4760 Stein Make Mill to IB Thermal Power Station.
Tender Issue Date:	15 th November 2016
Document Issue/Sale Close Date	23 rd November 2016 up to 17.00 hours.
Bid Submission Date	28 th November 2016 up to 15.00 hours
Bid Opening Date(Technical)	28 th November 2016 at 15.30 hours
Contact Info	Deputy General Manager, Purchase Materials. IB Thermal Power Station. Banharpali, Jharsuguda; PIN-768234. State: Country: INDIA. Telefax: 91-6645-289355; Cell no: 91-7682854468 Mail: bhadoo.jojowar@opgc.co.in ;
	Sr. Manager, Purchase Materials. IB Thermal Power Station. Banharpali. Jharsuguda. PIN-768234. State: Country: INDIA. Telephone: 91-6645-289355; Cell no: 91-9337287549. Mail: bn.das@opgc.co.in ;
Cost of Tender Paper	NIL. It may be downloaded from opgc website.
Earnest Money Deposit	Rs.1, 00, 000.00 (Rupees One lack only).

Note: Before Submission of bid please ensure proper documentation is made in technical bid and price bid as mentioned in the bid.

Deputy General Manager, Purchase Materials



NIT NO. - ITPS(PURCHASE) / 2016-2017 / 11 (P) dt.24/10/2016

Sealed bids in '**Two Bid System**' and in the prescribed format are invited from bona fide and financially sound reputed Manufacturers Only for supply of the following item IB-Thermal Power Station, Banharpali.

Tender Document will be available free of cost as per schedule mentioned upto 17:00 Hrs. from the office of the Deputy General Manager, Purchase Materials, ITPS, Banharpalli, Jharsuguda. **Detailed NIT is also available at our website www.opgc.co.in.** Any amendment and corrigendum to this NIT shall be posted in OPGC web page only.

Firms are requested to visit our website regularly for any amendment of the present bid till finalisation of bidding process and information for participation against various tenders. Tender documents can also be downloaded from our website.

M/s OPGC Ltd. reserves the right to accept/reject/split any tender without assigning any reason thereof and will not be responsible for any delay in postal/courier.

Firms interested for registration for supply of different materials may submit application in the prescribed vendor registration format available in our website.

Deputy General Manager, Purchase Materials

SAFE & CLEAN POWER IS OUR COMMITMENT

Tender Specification For Supply of Different Sizes of Hi Chrome Liners for BBD 4760 Mill.

IB Thermal Power Station, At/PO: Banharpali, Dist. Jharsuguda (Odisha), PIN: 768234 is a unit of Odisha Power Generation Corporation Limited a Joint Venture of Govt. of Odisha and AES America and engaged in generation of 2x210 MW Thermal Electric Power. The Plant site is about 17 Kms. from Belpahar Railway Station and 40 Kms. from Jharsuguda Rly. Station on S.E. Rly. on the Mumbai- Howrah main line.

Sealed tenders are invited from the reputed potential manufacturers only in their own letter heads for supply of different sizes of Hi Chrome Mill Liner for BBD 4760 Stein Make Ball Mill of IB Thermal Power Station as per specification mentioned as under.

Sl. No.	Item Code	Item Description (please follow the attached drawings)	Unit	Qty
1	466510107	Cylindrical Liner Var.01 (high chrome)	NO	160 no
2	466510108	Cylindrical Liner Var.02 (high chrome)	NO	160 no
3	466510109	Cylindrical liner with oblique wave I ((high Chrome)	NO	30 no
4	466510110	Cylindrical liner with oblique wave II ((high Chrome)	NO	30 no
5	466510111	Cylindrical liner with oblique wave III ((high Chrome)	NO	30 no
6	466510112	Cylindrical liner with oblique wave IV ((high Chrome)	NO	30 no
7	466510113	Boltless Filler Bar Type-I liner (((high Chrome)	NO	60 no
8	466510114	Boltless Filler Bar Type-II liner ((high Chrome)	NO	60 no
9	466510115	Conical Liner ((high Chrome)	NO	120 no
10	466510116	Hardware for liner	SET	01 set
11	466510117	Backing Material for liner	SET	01 set

NB: Please refer the drawing attached at ANEXURE- I to XI Page-34 to 44

The bid will consist of two parts. Both the parts should be placed separately and to be submitted together in a single envelope on or before Bid Opening date.

1st Part bid:

This envelope is to be superscripted with "Enquiry no., BOD, 1st part: EMD + Qualifying Requirements + Techno- Commercial Bid"

2nd Part bid:

This envelop should contain Price Bid and should be superscripted with "Enquiry No. , PRICE BID".

PART-1 TECHNICAL BID

(I) Minimum Qualifying Criteria:

Technical Requirements:

- a. The bidder must be a manufacturer. The documents in support of manufacturing capacity (installed & utilized), testing facilities must be furnished along with the tender. Status of the firm i.e. Company registration Certificate/ Partnership deed/ Proprietorship documents to be submitted.
- b. The bidder must have supplied the same materials with same composition to Thermal Power Plant in PSU Sector/ Govt. or any other Power Sector with credential of supplying 02 (**two**) sets of Liners in Hi-Chrome composition to similar type of coal mill BBD 4760 in preceding **five years** ending last day of the month previous to the one in which offers are invited. The bidder should have supplied minimum on set of liner within one year ending last day of the month previous to the one in which offers are invited.
NOTE: There are 11 (Eleven) items altogether in a set of liner out of which 9 items (Sl.Nos.01-9 of the set of a liners) are different types of liners. There may be bidders who have not supplied all the items in single order but have credential of supplying these liners in different orders will also be considered who have qualified the required criteria.
- c. Liners supplied by bidders should have been in operation with satisfactory performance in Coal Mill BBD-4760/4772 for a minimum period of one year from the date of installation of the same. Documentary evidence on above duly certified by the customers must be furnished along with the Tender. Self-certified copies of P.O. for the same items along with execution certificate and performance certificate from the customers should be submitted with the Tender. Bidders were also permitted to supply bought out matching fasteners subject to inspection for quality by third party inspection Agency at the place of manufacture.
- d. Bidder shall submit One order along with execution certificate (Completion of supply) with value of not less than Rs.80.00Lakh, Two orders not less than Rs.50 lakh and Three orders of not less than Rs.40.00Lakh of supply of high chrome liner. Bidder may submit invoice copies along with dispatch particulars in support of supply where they do not have completion certificate.
- e. The bidder should have heat treatment facilities and testing facilities for High Chrome liners. The testing facilities shall include spectrometer hardness tester and microscope of magnification 1000X minimum for microstructure analysis. The bidder has to confirm their availability and availability of calibration certificates of the machines. Documents in regard to Heat treatment / Quality Control facilities as mentioned to be submitted.

Financial Criteria:

- a. The average annual turnover of the bidder in the preceding three (3) financial years as on date of bid opening shall not be less than Rs.1.00 Crores.
- b. Annual accounts report of preceding three financial years including profit & loss account and balance sheet as certified by auditor.
- c. Requisite EMD shall be submitted along with techno commercial offer.
- d. PAN No.; VAT No. Photocopy of the certificates to be submitted. (Not applicable for overseas vendor. Export license if applicable to be submitted).
- e. Latest Solvency Certificate from any schedule Bank indicating the monetary limit upto which the bidder can be treated as solvent.

Other income shall not be considered for arriving at annual turnover.

Notes: In case where audited results of the last preceding financial year are not available, certification of financial statements from a practicing Chartered Accounts shall also be considered acceptable.

Notwithstanding anything stated above, OPGCL reserve the right to assess the capability and capacity of the bidder to perform the contract, should the circumstances warrant such assessment in the overall interest of the OPGC.

Note – Documents submitted by the bidder are presumed to be genuine. At any stage, before and after award of Order, if any of the submitted documents is found to be fraudulent /fake, OPGCL reserves the right to cancel the Offer / Order as well as take punitive action as per contract, including debarment of the bidder in future tendering. The documents submitted must be clear, legible in all respect.

Chemical composition:-

1.	Carbon:	2.4 to 2.8%
2.	Chromium:	22 to 28%.
3.	Manganese:	0.5 to 1.5%.
4.	Silicon:	1.0% (Max).
5.	Nickel:	0.5%(Max)
6.	Molybdenum:	0.6%(Max)
7.	Copper:	1.0%(Max)
8.	Phosphorus:	0.06%(Max)
9.	Sulphur:	0.06%(Max)

Metallurgical properties for liners:-

- i) Retained Austenite: Less than 5%.
- ii) Hardness: 56 to 62 RC.
- iii) Primary structure:-Primary carbides in Martensitic Matrix.

The scope of supply also includes free supervision by the successful bidder for erection of the subject liners and quarterly assessment of wear rate of liners.

Microstructure: Wholly tempered martensitic with trigonal (Fe-Cr)₇ C₃ type finally dispersed, complex carbides. All other details e.g. finish, freedom from defects, scales, burns, heat treatment and other defects shall be as per relevant IS.

A. PRODUCTION FACILITIES :

- a) Solid state controlled medium frequency induction melting furnaces for rapid and homogeneous alloy melting.
- b) High pressure rapid mechanized moulding line.
- c) Integrated on line automatic sand plant complete with knock off machine, cooling system, cyclone separator and magnetic particle separator.
- d) Precise control of pouring temperature by immersion pyrometer.
- e) Core sand mixer and electric core oven.
- f) Rotating Breaker Drum for effective segregation of physically defective grinding media, runners & risers etc.
- g) Facilities for manufacturing both liners and grinding media in order to ensure good compatibility and thereby derive optimum performance.

B. HEAT TREATMENT FACILITY

- a) Computer controlled programmable multi zone continuous pusher type furnace with multipoint Auto temperature controllers/recorders.
- b) Electrically heated bogie hearth furnace.
- c) Air and Oil quenching terminals.
- d) Tempering furnaces with air circulation for imparting precise heat treatment cycle appropriate to specific alloy grade.

C. QUALITY CONTROL FACILITIES

- a) On line chemical analysis facilities involving computerised vacuum emission spectrometer with reading element accuracy up to 0.001 % with ferrous background and with microprocessor base.
- b) Leco Carbon - Sulphur determinator for accurate and rapid analysis of carbon and sulphur.
- c) Metallurgical microscope for macro and micro structure evaluation.
- d) Full fledged control laboratory for evaluating hardness, impact and other mechanical properties.
- e) Spark erosion machine for sampling for measurement of retained austenite and core hardness without affecting metallurgical structure.
- f) Sigma meter to measure through specialised testing, the retained austenite level.

Retained austenite is to be strictly maintained below permissible limit as hard working conditions in tube mills can result in retained austenite getting converted to martensite resulting in volume expansion leading to : - excessive wear & breakage.

D. APPROVAL: Vendors shall have to submit their QAP of the manufacturing along with the technical bid. OPGCL may prefer the manufacturers assessed and approved by M/s Stein Industries, France (M/s ALSTOM POWER)/BHEL /NTPC.

E. DESIGN CAPABILITY :

Design capability with facility of test mill at works for wears assessment. Satisfactory performance reports from users for above supply for wear rate established should be furnished.

F. GUARANTEE: Wear Rate Guarantee: The guaranteed life of the liners shall be 30,000 running hours without reversal from the date of putting them in service for all types of Indian coal. The bidder shall replace the liners free of cost for life below 20,000 hrs. without reversal from the date of putting them in service and a pro-rata deduction shall be made for life in between 20,000 – 30,000 Hours.

G. All testing of the product shall be guided by QAP enclosed herein after and is binding to the manufacturer. All relevant test documents, duly approved by the third party & Guarantee certificate are to be furnished along with the consignment.

H. The materials are to be dispatched after clear acceptance of all test reports & related documents by third party inspecting agency approved by OPGCL.

I. The bid security shall remain valid for a period of One Hundred Eighty (180) days.

J. ANY BID NOT ACCOMPANIED WITH AN ACCEPTABLE EMD (BID SECURITY) SHALL BE REJECTED BY THE EMPLOYER AS BEING NON-RESPONSIVE AND RETURNED TO THE BIDDERS WITHOUT BEING OPENED.

K. Payment Terms: The bidder has to accept our payment terms i.e. 90% payment shall be made within 30 days from the date of final acceptance of material & 10% shall be made within 90 days on submission of 10% of PO Basic value as performance bank guarantee valid for a period of 21 months (18 months + 03 months grace period) from the receipt of materials or 15 months (12month + 3months grace period) from the date of use whichever is earlier. All payment shall be made in electronic mode. E-mandate to be submitted for release of payment.

- a) **Security Deposit:** The bidder shall submit security deposit i.e. 05% of the P.O. basic value in shape of DD/irrevocable bank guarantee valid for six month/up to delivery period whichever is later plus 2 month claim period from a nationalised bank executed on non-judicial stamp paper of appropriate value towards execution of the contract. Security deposit shall be released after supply is complete. If the Supplier fails or regrets to observe or perform any of his obligations under the Contract, it shall be lawful for the Purchaser to forfeit either in whole or part, in his absolute discretion, the security-deposit furnished by the Supplier. The forfeiture of Security deposit shall be without prejudice to the right of the Purchaser to recover any further amount of any liquidated and / or other damages, undue payment or over payment made to the Supplier under this contract or any other contract. No claim of the Supplier shall be entertained against the purchaser either in respect of interest or depreciation in the value of Security deposit. Security deposit is to be submitted within 30 days of placement of LOI/PO.
- b) **Guarantee:** The bidder shall have to confirm that guarantee period of 12 months commencing from the date of utilisation or 18 months from the date of last despatch whichever is earlier for defects in material and workmanship. The materials also shall be guaranteed for the chemical composition and hardness as specified for the above mentioned period.
- c) **Inspection:** The bidder has to clarify to accept our inspection by third party. Third party inspection charges if any to be clearly specified. The details of test procedure followed after manufacturing shall have to be mentioned in the techno commercial bid. Test certificate shall be submitted in the supply documents.
- d) The bidder has to submit their valid BIS/ISO registration certificate or any other international accreditation documents.
- e) **Delivery:** The bidder has to clarify to deliver the material within eight weeks with pre despatch inspection by M/s OPGC and/or Third party from the date of receipt of our order/LOI .However OPGCL shall have the right to purchase / cancel at any point of time. Schedule of delivery shall be a point for consideration during evaluation of the bid. *Delivery shall be made in a single lot basis.*
- f) **Validity:** The price shall remain valid for a period of 180 days from the date of opening of techno-commercial bid. The price should be firm for two years for staggered delivery schedule.
- g) **Termination of Contract:** The purchaser has to right to terminate the contract at any time.
- h) **Dimensions:** Information on shipping weight and cubage (length, width & height) to be provided.
- i) Any deviation from above points shall have to be mentioned clearly in the techno commercial bid.
- j) **Despatch:** The consignment shall be despatched to IB Thermal Power Station to the consignee on door delivery and freight paid basis after necessary inspection by third party and despatch instruction by OPGC Engineer.
- k) **Standard:** The material to be supplied shall be strictly as per relevant IS. Quality Assurance Plan to be approved by OPGCL before manufacturing.
- l) **Inspection/Testing:** Pre despatch Inspection & Testing shall be carried out by Us/Third Party at your works by your cost. Metallurgical Test Report from govt. Approved Laboratory to be submitted along with the supply. OPGCL may incorporate any other testing or inspection if required at your cost. If required, the third party may take the samples to outside for necessary testing on their behalf. Finally, he will certify regarding acceptance of the material. Regarding inspection, necessary communication with the third party has to be made well in advance by the party, matching their production planning.
- m) **Samples:** If required M/s OPGCL shall ask for samples drawn from each consignment in the presence of company's authorised representative and arrange testing in an independent laboratory to check up whether the supplied item are in accordance with the purchase order or not.
- n) **Inspection Details:**
- Dimensional Check of 1 piece for each 10 number of liner selected at random from each size along with visual check shall be done first.
 - Hardness at core and surface of liner selected randomly of 1 piece for each 10 number of liner .The hardness shall be as per specification mentioned.
 - Chemical Check test at one liner per cast to be presented for inspection.



- Each liner must be embossed for identification.
 - If required inspection of raw material or other stage inspection shall be done by OPGCL or its approved Third Party Agency.
- o) **Quantity Variation:** The quantities mentioned in the tender may be changed at the time of order.
- r) **Risk Purchase:** The inability of the bidders to execute the order in accordance with delivery schedules will entitle M/s OPGCL to purchase the orders at the risk and cost of the vendors from other sources. The difference in amount shall be recovered from the dues of the vendors. Increase in tax structure due to delay in supply beyond contractual delivery period is to vendor account.
- s) **Laws of Governing Contracts:** All Contracts shall be governed by the laws of India for the time being in force. Irrespective of the place of delivery, place of performance or place of Payment under this contract, the contract shall be deemed to have been made at place from Which the acceptance of tender has been issued.

Deputy General Manager, Purchase Materials

(V)TENDER NOTICE GENERAL TERMS & CONDITIONS

1. Sealed Tender is invited (in duplicate) for the supply of articles as per details mentioned in the bid. Tender should be submitted in a proper sealed envelope addressed to the Manager (Purchase Materials); Purchase Department OPGCL- IB Thermal Power Station, Banharपाली, Jharsuguda-768234, in variably giving on the cover Tender Notice No., Name of the Articles, and the date of opening and EMD details.

- 2 Basic Qualification of Bidders

This bidding is open to any Manufacturer/ Supplier who provides satisfactory evidence that he (Bidder):-

- (a) Is a qualified manufacturer or an authorized representative of a qualified manufacturer who regularly manufactures the equipment of the type specified and has adequate technical knowledge and practical experience.
 - (b) Does not anticipate change in the ownership during the proposed period of work (If such a change is anticipated, the scope and effect thereof shall be defined).
 - (c) Has adequate financial stability and status to meet the financial obligations pursuant to the scope of the assignments (The bidders should submit at least 3 copies of their profit and loss account and balance sheet for the preceding 3 years, including turn over).
 - (d) Has adequate plant and manufacturing capacity available to perform the assignment properly and expeditiously within the time period specified. The evidence shall consist of written details of the installed manufacturing capacities and present commitments (excluding the assignments under this specification) of the bidder or his Principal. If the present commitments are such that the installed capacity results in inadequacy of the manufacturing capacities to meet the requirement of equipment corresponding to this bid, then the details of alternative arrangements to be organized by the bidder for this purpose and which shall meet the owner's approval shall also be furnished.
 - (e) Has established quality assurance systems and organization designed to achieve high levels of equipment reliability during his manufacturing activities.
- 3 Amendment in Specifications: OPGCL may revise or amend the specification and drawings prior to the date notified for opening of tenders. Such revision / amendment, if any, will be communicated to all bidders as amendment / Addendum to the specification which will also be published in OPGC web site. Vendors may visit our website regularly till finalization of tender.
 - 4 **Requirement to read the Tender Specification by Bidder**: The bidders are requested to go through all the contents of Tender specification before preparing their tender / bids for submission **[Refer the drawings attached as ANEXURE-I to XI at Page-34 to 44].**
 - 5 The quantities mentioned in the Tender Notice shall be deemed to be only approximate and will not in any manner whatsoever be binding on the OPGCL- IB Thermal Power Station.
 - 6 All tenders are to be submitted up to 15:00 hours on the opening date & they will be opened at 15:30 hours on the same date specified. Representatives of the bidders those who choose to be present may attend the bid opening.
 - 7 The tender shall remain open for acceptance for a period of **180 DAYS FROM THE DATE OF OPENING UNLESS OTHERWISE SPECIFIED**. Tenders with a Validity of Less than **180** days are liable to be rejected/ or have lesser preference than those adhered the tender conditions.
 - 8 Actual percentage of Duties/Sales tax (Local or Central or Both) of any description whatsoever where leviable and intended to be claimed from the OPGCL-IB Thermal Power Station, whether as a part of the price or by way of tax in purchase of any statutory provisions enabling the dealer to collect the Sales Tax/Excise Duty leviable on him for purchase should be distinctly shown along with the price quoted. Where it is not done all claims for payment or reimbursement of Sales Tax/Excise Duty any description whatsoever whether part of the price or extra will be deemed to have been waived and such claims shall not be entertained on any ground whatsoever.
 - 9 TIN No/ VAT No. SALES TAX REGISTRATION NUMBER MUST BE INDICATED IN VARIABLY FAILING WHICH OFFER SHALL NOT BE CONSIDERED.

- 10 Rates quoted should be F.O.R. IBTPS, Bahhaprali. In case rates Ex-go down shops , indicate actual amount of Packing and Forwarding charges and railway freight/Road freight up to destination, IB Thermal Power Station, Bahhaprali, Jharsuguda, Odisha. Jharsuguda is our nearest transport go down which is 40 Kms from IB Thermal.
- 11 Wherever bidders have entered into the Rate Contract with Director General of Supplies and Disposals they will indicate the same in their tender. They will also certify that the rates quoted are same as are applicable on the rate contract finalized by the Director General or Supplies & Disposals.
- 12 Illustrated pamphlet/leaflet and drawing indication technical details/Year of manufacture, Maker's Name, Country of Origin etc. must be enclosed with tender.
- 13 SPECIAL ATTENTION OF THE TENDER IS INVITED ABOUT THE RECEIPT OF TENDER IN TIME. TENDERS RECEIVED AFTER THE STIPULATED DATE AND TIME DUE TO ANY REASON WHATSOEVER SHALL NOT BE CONSIDERED TENDERERS ARE REQUESTED TO SEE THAT THE TENDERS ARE DELIVERED IN THE OFFICE BEFORE THE PRESCRIBED DATE AND TIME.
- 14 The delivery period quoted must be specific and realistic. The inability of the successful tenderers to execute orders in accordance with delivery schedules will entitle OPGCL to purchase the stores at the risk and cost of the contractors such failures will also be kept in view while considering that subsequent tenders.
- 15 With regard to acceptance of tender for earlier delivery it should be noted that if the contract is placed on higher tender in preference to the lowest acceptable offer in consideration of earlier delivery the contractor will be liable to pay to OPGCL, the difference between the contract rate and the lowest acceptable, in case of failure to complete suppliers in terms of such contract within the date of delivery specified in the tender and incorporated in the contract. This is without prejudice to other rights of the OPGCL under the terms of contract.
- 16 The time given for delivery or dispatch shall commence from receipt of the purchase order by the contractor. The time for and the date of delivery of dispatch stipulated in the schedule for the delivery or dispatch of stores shall be deemed to be the essence of contract and should the contractor fail to deliver or dispatch the stores or any consignment thereof within the period prescribed for such delivery or dispatch the purchased shall be entitled to withhold payment until the whole of the stores have been supplied and to recover from the contractor a sum of the half percent of the price of any stores which the contractor has failed to deliver or dispatch aforesaid for each and within week or part of a week during which the delivery OR dispatch of such stores may be in arrears subject to maximum of five percent of total of the contract value alternatively at the option of the Purchase shall be entitled to purchase also where on the account & at the risk of the contractor the store of any consignment thereof which the contractor has failed to deliver or dispatch as afore said if not available the nearest available substitute thereof to cancel the contract and the contractor shall be liable for all loss or damage which may sustain by reason of such failure on the part of the contractor.
- 17 Suppliers failing to execute the order placed on them to the satisfaction of OPGC under the terms and conditions set forth therein, will be liable to make good the loss sustained by the Board, consequent to the placing of fresh orders elsewhere at higher rates, i.e. the difference between their ordered price and the price accepted in the contract already entered into the price at which fresh orders have been placed. This is without prejudice to the imposition of liquidated damages.
- 18 It is a condition of the contract that all though the currency thereof, the price at which the tender shall supply stores shall be firm.
- 19 Tenderers may kindly note that it is essential to pay the requisite amount of earnest money in any one of the following form.

Demand Draft/Bank Guarantee from a Nationalized Bank irrevocable and operative till the validity of the offer. The earnest money will be liable to be forfeited on revocation of the quotation expired if refused to enter into a contract after the award is made to the tenderer.

- 20 Small scale industries/National Small Scale Industries Corporation shall be exempted from payment of Earnest Money Deposit/Tender Fees only if they are entitled for exemption of the offered items. Tenderers seeking exemption should enclose a photocopy of valid registration certificate with NSIC.
- 21 Successful tenders will have to deposit security by the date specified in the Acceptance of Tender in case they fail to deposit security by the specified date the OPGCL reserves the right to adjust the same from the payment pending with the OPGCL, ITPS, and Banhaprali.
- 22 OPGCL reserve the right to give preference to those quoting payment and delivery as per bid norms. Loading shall be made for other terms of payment and delivery.
- 23 OPGC reserves the right not to accept the lowest rate quoted by the Bidder and may reject any or all the tenderers and to split-up and award the order to more than one tenderer without assigning any reasons whatsoever.
- 24 Wherever samples are asked from tenderers the same shall be submitted freight paid through post of Railways/Road Transport and should reach the OPGCL within the stipulated date and time failing which to cognizance will be given to such samples which are received late.
- 25 Printed Terms and Conditions on letter heads or Quotation form of tenderers shall not be applicable.
- 26 Tendering firms are advised to quote as per our serials number specified in tender notice.
- 27 OPGCL Reserves the right to reject all or to any of the tenders or to accept the tender or to accept the tender either in full or in part or to split of the contract without assigning any reason.
- 28 The quote price discount if any should be typed both in words as well as in figure without any cover typing. Alternations if any should be made clearly by crossing already entered rates and all such corrections should be attested by the tenderers under their full signature in no case there should be over writing and all tender with such over writing and all tender with such over writing shall be liable for rejection.
- 29 Our Tender Notice No. & due date of opening nature of items and vendors complete address should in variable be indicated on the top of the envelope, Bank charges always borne by the vendor.
- 30 Wherever I.S is available please quote as per I.S only, otherwise quote the brand name of the quote items goods must be dispatch through authorized dealer.
- 31 The material supplied shall be guaranteed for a period of 18 months from the date of supply or 12 months from the date of actual use whichever is earlier.
- 32 These terms and conditions shall form a part of the contract.
- 33 EFFECTING OF RECOVERIES:** Any loss, arising incident to non-fulfilment of this contract or any other contract, will be recovered from the Security Deposit held and or any other amount due to the supplier from OPGC.
- 34 **PATENT RIGHT ETC:** The Supplier shall indemnify the purchaser against all claims, actions, suits and proceedings for the infringement or alleged infringement of any patent, design or copy right protected either in the country of origin or in India by the use of any equipment supplied by the supplier other than for the purpose indicated by or reasonably to be inferred from the specification.
- 35 **Jurisdiction:** All contracts effected between OPGCL and vendor shall be subject to Jharsuguda Court Jurisdiction and shall be governed by Law. It is agreed that no other court shall have jurisdiction to entertain any suit or proceedings, even though, part of the cause of action might arise within their jurisdiction. In case any part of the cause of action might arise within the jurisdiction of any other Courts in Odisha, and rest within the jurisdiction of Courts outside the State of Odisha, then it is agreed to between the parties that such suits on proceedings shall be instituted in a Court within the State of Odisha and no other Court outside the State of Odisha have jurisdiction.
- 36 **Arbitration:** In case of any dispute arising out of the supply or interpretation of meaning of the terms in these conditions of purchase or any alleged breach thereof, the same shall be referred to independent Arbitrator/s selected by the aggrieved party and consented by the other party. The arbitration shall be conducted in accordance with the provision of Indian Arbitration Act of 1996 or modifications thereof and award of Arbitrator shall be final and binding on both parties. The arbitrations shall be conducted at Jharsuguda or at such place as decided by Arbitrator. The cost, incidentally shall be borne by the vendor.
- 37 **Litigation:** All expenses and cost in connection with litigation, if any, will be to vendor account.

38 (a) Preparation of comparative statement:

The Proforma for comparative statement has been standardized and is as per annexure of manual. CS should be prepared as per proforma and loading actors to be used for loading are as mentioned below (if not mentioned specifically in the offer).

P&F charges	2%
Freight	2%
300 Kms. to 500 Kms.	3%
500 Kms. To 1000 Kms.	4%
Above 1000 Kms.	5%
Insurance	0.086%

(NOTE: Percentage loading will be limited to full truck/trailer load rate for each truck load).

(b) Payment terms loading

1.5% per month (wherever parties have quoted 100% through bank/advance against our standard and payment terms of bid documents).

In case of payment through bank loading for a period 30 days and in case of advance payment along with P.O. the loading for the period of delivery period plus 30 days, may be taken. In case of 90% through bank & balance 10% within 30 days after receipt and acceptance of materials.

Loading factor will be $1.5 \times 0.9 = 1.35\%$. Accordingly for other payment terms loading factors will be calculated.

(C) Delivery term loading: If the delivery period required as per bid requirement is deviated the loading shall be done @0.5% per week or part thereof for the period over and above the stipulated delivery period.

(D) If the PBG clause is not accepted or deviated loading for the same shall be done.

Loading procedures

DI) Basic Price.	
DII) Packing & Forwarding charges	(on basic price only)
DIII) Excise Duty on	(Basic + P&F)
DIV) Sales Tax on	(Basic + P&F+ ED)
DV) Freight on	SUM (DI to DII) or Else stated
DVI) Insurance on	(Basic + P&F + ED+ ST+ Freight)
DVII) Payment Terms Loading on	(Basic + P&F + ED + ST+ Freight)

In case on variable prices, Variable excise duty etc. the following norms/systems will be taken into consideration.

(a) In case of price variation clause (without specific mention of quantum), 10% price escalation per annum may be proportionality loaded.

(b) In case of the bidder stipulates Excise Duty as applicable at the time of dispatch & specifies the present rate of Excise duty (a numeric percentage or nil), in such case the offer shall be evaluated considering the maximum rate of E.D. applicable for the product as per Excise Tariff of Govt. of India or as evident from the other bids received in the tender.

However, the liability of OPGCL shall be as per actual ED applicable at the time of dispatch, subject to production of Excise invoice. Further the rate of ED shall be restricted to as applicable within the contractual delivery period only. Increase in ED rate if any due to delay in supply beyond the contractual delivery period shall not be payable by OPGCL. However the benefit of any decrease in ED shall be passed on to OPGCL.

In case bidders quote with Fixed Rate of ED OR Special ED as NIL" the offer shall be evaluated accordingly. This will be subject to submission of Excise invoice copy for having actually paid the Excise Duty or otherwise but claim for any upward revision will not be accepted at a later stage.

(Adverse loading in each factor to be done for comparison purposes, in case vender has not mentioned specifically however, for placement of order the lowest/beneficial terms will be indicated.)

IMPORTANT NOTICES:

1. Please fill in the proforma for summary quotation as per specimen given.
2. Tenders not specifying the exact rates of taxes and duties (wherever applicable) shall be loaded to the highest slab or may not be considered.
3. **Any deviation in Technical Specification/ terms & conditions shall be clearly specified in details in the deviation statement , failing which shall be deemed the NIT specification & Terms conditions are acceptable in totally unless and otherwise specified in the deviation statement. Deviations mentioned at any other points may not be acceptable and the bid may be treated as unresponsive and in such case bid may be rejected and EMD amount shall also be rejected.**
4. The suppliers/contractor is required to manufacture the product/carryout the work in controlled condition so as to contain Air pollution, water/land contamination within relevant legislative & statutory requirement.
5. Vehicle must accompany TREM Card for transportation of materials wherever applicable to OPGCL. Driver must carry valid driving license for transporting the materials to OPGCL.
6. Vendor/Representative/Vehicle driver must wear Safety Helmet, Shoes inside the Plant premises.
7. All person(s) connected with OPGCL shall have to adhere the safety rule regulations of the Company.
8. Salient points of EHS (Environment Health & Safety) that are to be considered while submission of offer are:
 - a. Consumption benchmarks related to output shall be provided wherever applicable for key input resources (energy/fuel/chemicals).
 - b. Competency requirements for operation, maintenance and calibration if any.
 - c. MSDS to be submitted in case any hazardous chemicals as per MSIHC (Manufacturing, Storage, Import of Hazardous Chemicals (Rules 1989/94/2000 along with onsite and offsite emergency plan (as applicable).
 - d. Occupational and Health safety control measures for safe working of the equipment offered.
 - e. Equipment should be fitted with guard for rolling and moving part as per OH&S legislation and Factory Act.
 - f. The recommended PPE for the equipment to be furnished.
 - g. Details of all hazardous/harmful substances discharged as by-products/wastes during operations to be mentioned along with their permissible limits.
 - h. Appropriate pollution controls measures to be taken to keep the emissions from the battery to be clearly mentioned.
 - i. Chemical banned due to their negative impact on the environment shall not be used in the offered item.
 - j. Details of disposal practices to be followed to be provided for the chemicals and the equipments.
 - k. Primary materials used in the equipment shall be specified and they should be ecofriendly.
9. Vendor shall take all measures necessary steps to maintain integrity in totality throughout the bidding process. He or any of the representatives, third person shall not be engaged in any manner to anybody in the business at any point of time for biasing or indulged in corruption process during any stage of bidding process (pre contract or post contract stage) in order to secure the contract or in furtherance to secure it. Indulgence of such unfair practices will lead to Cancellation of bids or orders as the case may be and also lead to forfeiture of EMD, Security deposit and performance bond without assigning any reason thereof. Similarly if any person from the purchaser OPGCL demands or do any unlawful act are to be brought to the notice of the management to address the same. If required OPGCL & Vendor have to sign the Integrity Pact to maintain the transparency in the procurement process as per format enclosed.
10. OPGCL reserves the right not to accept the lowest rate quoted by the bidder and reject any or all the offer without assigning any reason whatsoever. M/s OPGC Ltd. also reserves the right to accept/reject/split any tender without assigning any reason thereof.

Deputy General Manager, Purchase Materia



QAP FOR HI-CHROME LINERS

Sl. No.	Component & operation	Characteristics	Class	Type of Check.	Quantum of Check.	Reference Document	Acceptance Norms.	Format of record.	Agency		Remarks
									M	C	
1.00:- IN PROCESS INSPECTION											
1.1	Molten Metal	Chemical properties	Critical	Ladle analysis	1 sample per heat	As detailed below	As detailed below	Test certificate	P	W	
1.2	Hi-Chrome Liner casting.	Surface examination	Major.	Visual	100%	Do	Do	Do	P	R	
1.3	Do	Heat Treatment	Critical	HT Chart	Each HT batch.	Do	Do	HT Chart.	P	R	
1.4	Do	Hardness	Critical	Measurement	1 sample per HT batch	Do	Do	Test certificate	P	R	
1.5	Do	Dimensions	Major.	Gauges/ Templates	100%	Approved drawing.	Approved drawing.	Certificate	P	R	
2.00:- FINAL INSPECTION											
2.1	Hi-Chrome Liner	Surface Hardness	Critical	Measurement	10% at random	As detailed below	As detailed below	Test certificate	P	W	
2.2	Do	Micro examination	Critical	Microstructure	1 sample per HT batch	Do	Do	Do	P	R	
2.3	Do	Retained Austenite	Critical.	RA Measurement	1 sample per HT batch	Do	Do	Do	P	R	
2.4	Do	Dimensions	Major	Gauges/ Templates	10% Random	Approved drawing.	Approved drawing.	Do	P	W	
2.5	Do	Surface examination	Major	Visual	10% Random	As detailed below	As detailed below	Do	P	W	

M-Manufacturer; C-Customer or Customer nominated Agency, P-Perform, W-Witness, R -Review.



01. Chemical composition:-C:-2.4-2.8% ; Mn:-0.5-1.5% ;Cr.:-22.0-28% ; Ni:-0.5%(Max) ;Si:-1.0% Max ;Cu:-1.0% Max; Mo:-0.6% Max; S-0.06% Max; P-0.06% Max.
02. Hardness:-56 to 62 HRC.
03. Heat Treatment:-
 - a) Hardening:-Heating up to 850-950 deg C and air quench.
 - b) Tempering:-Heating up to 275-325 deg C and cooling in air.
04. The microstructure of the castings after Heat Treatment shall consists of primary carbides in martensitic matrix. Retained austenite shall be 5% maximum.
05. Acceptance norms for surface defects:-
 - a) Sand & sand inclusions, blow holes:-Depth of defects should be less than 5.0 mm. Severity level as per DIN 1690 part-II.
 - b) Riser and ingate undercut in to parent metal should be less than 7.0 mm .Area of undercut same as riser pad and ingate area.
 - c) Riser pad may be left unground in the recess portion of the fitting face.
 - d) Cracks due to grinding may be present and are acceptable.

QAP FOR LINER BOLTS, NUTS, WASHERS & BACKING MATERIALS

Sl. No.	Component & operation	Characteristics	Class	Type of Check.	Quantum of Check.	Reference Document	Acceptance Norms.	Format of record.	Agency		Remarks
									M	C	
1.00:- RAW MATERIAL INSPECTION											
1.1	Round for Bolt	Chemical	Major	Chemical	1/Lot.	BS 970/EN 19	BS 970/EN 19	Lab Report.	P	R	
1.2	Round for nut & washer	Chemical	Major.	Chemical	1/Lot.	IS 2062/IS 226	IS 2062/IS 226	Lab Report.	P	R	
1.3	Rubber for washer & backing materials.	Polymer	Major	Polymer	1/Lot.	To withstand a temp. of 250 deg C.	To withstand a temp. of 250 deg C.	Lab Report.	P	R	
2.00:- FINAL INSPECTION											
2.1	Bolt, nut & washer.	Dimensional	Critical	Visual & dimensional.	10%	Approved drawing	Approved drawing	Report	P	W	
2.2	Bolt.	Chemical	Critical	Chemical	10%	BS 970/E-19	BS 970/E-19	Report	P	R	
2.3	Bolt	Hardness	Critical.	Hardness	10%	270-350 BHN	270-350 BHN	Report	P	W	



DEVIATION FROM Techno- COMMERCIAL SPECIFICATION

All Deviations from the Commercial terms shall be filled in by the Tenderer, Clause by Clause, in this Schedule else bid may be treated as unresponsive. Deviations which are not reflected in this sheet and found at any other point shall not be considered any in such case EMD amount may be forfeited.

Section No.	Clause No.	Deviation type & details	Remarks/ Page reference no.

The tenderer hereby certify that the above mentioned are the only deviations from the Techno Commercial terms of the Specification. Deviation points not mentioned in this list shall not be considered.

Company Seal:
Designation:
Company:

Signature:



**STATEMENT OF SUPPLY ORDERS EXECUTED / UNDER EXECUTION DURING
THE PAST THREE YEARS AS ON THE DATE OF TENDER**

Name of Equipment/Material	Name and Address of the Organisation.	Po No. & Date	Qty.	Value in Rs.	Schedule date of completion of order	Actual date of completion of order

Company Seal:
Designation:
Company :

Signature :

PROFORMA FOR SUMMARY QUOTATION

For Technical & un-priced Commercial bid) Part-1

Tender No.:

Sl. No.	Techno Commercial Points	OPGCL Needs	To be filled by the bidder with Page/Folio Reference
1	Technical Specification as per Tender Enquiry for supply of Hi-Chrome Liner for Ball Tube Mill.	a. Accepted/ Not accepted. b. If not accepted detail deviation and proposal.	
2	Credentials for supply of quoted items to other power plant.	Submitted/ Not submitted as per bid requirement.	
3	The bidders should have experience in design, manufacture, supply of Hi chrome Liner as per bid requirement and supplied a minimum of 2 sets out of which one set in last five year.(60 months within date of bid opening)	Yes/ No.	
4	The performance certificates from the industries where used, are to be enclosed. The Performance certificate should be submitted for the installations which are Commissioned in the last ten (10) years as on date.	a. Yes/ No. b. If Yes name of the Plant/s.	
5	Bidder is a ISO 9001/ISO14001/OHSAS18001 firm	Yes/No	
6	All Tests to be carried out as per the bid document	Yes/No	
7	Bidder has to submit EMD either in shape of DD payable on State Bank of India (Code No. 9510) Banharpali /Central Bank of India, Belpahar/ Andhra Bank, Adhapada (Code-0662), IB Thermal Power Station, Banharpali, Jharsuguda in favour of Odisha Power Generation Corporation Limited.	Submitted/Not submitted	
8	Price Basis	FOR Destination IB Thermal Power Station.	
9	Packing & Forwarding charges % or Rs..... in Lumpsum Inclusive/ Exclusive.	
10	Excise Duty % Inclusive/ Extra/Not applicable.	
11	Sales Tax/VAT % of CST/VAT inclusive or Exclusive. OPGCL will provide " C " form for interstate sale.	
12	Transportation Cost	Rs. ---- per No./Lump sum. As extra/Inclusive.	

13	Transit Insurance % extra/inclusive	
14	Odisha Entry Tax% inclusive/Extra	
15	Delivery Schedule	Six weeks Accepted/Not Accepted.	
16	Validity of offer	180 days from the due date of opening date of the Part-1 bid.(Techno Commercial). Accepted/Not accepted.	
17	Liquidated damage clause is applicable if delivery is delayed beyond quoted delivery date @0.5% per week/part of week subject to 5%of PO value.	Accepted/ not accepted. Non acceptance shall lead to loading of your offer by 5%.	
18	Submission of security deposit as per bid.	Accepted/Not accepted	
19	Payment Term: 90% payment shall be made within 30 days from the date of final acceptance of material & 10% shall be made within 90 days on submission of 10% of PO value as performance bank guarantee valid for a period of 21 months (18 months + 03 months grace period) from the receipt of materials or 12 months from the date of use.	a. Accepted/ Not accepted (in case non acceptance loading shall be done). b. If not accepted with deviation details.	
20	Acceptance of part order quantity	Yes/No	
21	Packing material as per OPGCL term to use non asbestos and environmentally friendly material	Yes/ No	
22	Payment to be made through RTGS mode	Accepted/ Not accepted.	
23	All Bank charges to vendor account	Accepted/ Not accepted.	
24	Tender Notice NIT General Terms & Conditions	Accepted/ Not accepted.	
25	Acceptance to guarantee clause	Accepted/not accepted.	
26	List of Deviation statement from tender norms.	Submitted/ Not submitted.	
27	Certificate of approval by BHEL/Alstom Power(Stein France)/NTPC	Submitted	
28	Average turnover in last three years. P/L account of last three year.	Document submitted/Not submitted.	

Authorised Signatory:
Name of the firm:
Designation:
Company Seal:
Place & Date.



Part-II

Part-II is the Price Bid only which should contain the price & details of break up of the trade discount, Packing, forwarding, Excise duty, Sales Tax, VAT, freight, insurance & Odisha Entry Tax. Supervision and Installation Charges, Third party inspection charges etc.

PROFORMA FOR SUMMARY QUOTATION for Price Bid (Part-II)

BIDDERS REF.:

DATE:

Sl No.	Description of the materials Equipment Service Item wise	UOM*	Qty. offered	Unit Rate	Price Basis	P&F*** Charges.	E.D.**	Sales Tax/ VAT	Estimated freight /Specify mode of transport	Transit Insurance (specify rate)	Odisha Entry Tax	Total price F.O.R. Destination
1	Cylindrical Liner Var.01 (High Chrome)	NO	160									
2	Cylindrical Liner Var.02 (High Chrome)	NO	160									
3	Cylindrical liner with oblique wave-I (High Chrome)	NO	30									
4	Cylindrical liner with oblique wave-II (High Chrome)	NO	30									
5	Cylindrical liner with oblique wave-III (High Chrome)	NO	30									
6	Cylindrical liner with oblique wave-IV (High Chrome)	NO	30									
7	Boltless Filler Bar Type-I liner (High Chrome)	NO	60									
8	Boltless Filler Bar Type-II liner (High Chrome)	NO	60									
9	Conical Liner(High Chrome)	NO	120									
10	HARDWARE FOR LINER	SET	1									



11	BACKING MATERIAL FOR LINER	SET	1									
----	----------------------------	-----	---	--	--	--	--	--	--	--	--	--

1. BANK CHARGES(IF ANY)
2. Third party INSPECTION Charges if any:
3. Super vision and installation charges:
4. (i) Deviation in tech. Specification- YES OR NO/ if yes details of the same.
(ii) Deviation in commercial Terms & conditions- YES OR NO /if yes details with clause No.

Authorised Signatory:

Name of the firm:

Designation:

Company Seal:

Place & Date



The above two bids should be sealed separately superscribing as Technical & Un-Priced Commercial (Part-I) and Price Bid (Part-II) as the case may be and enclosed in third sealed envelope superscribing NIT No. ITPS/(Purchase)/2016-17/17(P) Dt. 04-11-2016 for supply of High Chrome Liners to ITPS due on 28th November-2016 . Your offer should reach this office on or before 28th November-2016 up to 15.00 hrs. Part-I (Technical and Un-priced commercial Bid) shall be opened on same day at 15.30 hrs. in presence of either the bidder or their authorized representative. Parties who shall qualify in Techno commercial bid shall be intimated to attend on a future date & venue to keep them present in the opening of Price Bid. In case the tender opening date happens to be a holiday the same will be opened on the next working day.

The EMD of unsuccessful bidders shall be returned within 45 days of opening of the price bid. If the bids are not submitted in separate sealed envelope, both found in one envelope or if price bid is found in techno commercial bid and vice versa the bids will be rejected.

Offer received late due to postal or courier delay shall not be entertained. The bidder at their interest should ensure delivery of the bid well in advance.

OPGC shall not be responsible in any way for any delay/ difficulties/ inaccessibility of the downloading facility from the website for any reasons whatsoever. The tenderer(s) who are found to be indulging in changing/ adding or deleting the content of the downloaded Tender Documents will be liable to face necessary action as deemed fit including banning, suspension of business dealings etc. In case any discrepancies found between the downloaded Tender Documents from the website and the master copy available in the Office of the Tender Inviting Authority, the later shall prevail and will be binding on the Tenderer(s). No claim/ appeal on this account will be entertained or given cognizance. Tenderer(s) will be solely responsible for the correctness/ genuineness of the downloaded Tender Documents from the website. If the offer submitted through the downloaded tender documents which are incomplete, or with changed content, the offer will be summarily rejected. Quotation submitted by the tenderer(s) through FAX/ Telegram will not be considered valid.

M/s OPGCL reserves the right to ask more credential/clarification during evaluation of Techno-commercial bid and reserves to extend the date of opening of techno commercial bid & price bid. Any amendment or Bid extension shall be published in the opgc web page www.opgc.co.in only. M/s OPGCL reserves the right to accept, reject all or any bid & can split among the bidders or can ask for rebid among the technical accepted bidders without assigning any reason thereof.

N.B:- Evaluation of "L1" will be done for "Hi-Chrome Liners & fasteners including backing materials" under this NIT on the landed cost for sum total of quoted rates for all items including taxes, duties, freight, third party inspection charges & other costs indicted in the price bid.

Deputy General Manager, Purchase Materials

Additional Instructions for Foreign Bidders.

1. The Price basis shall be CIF Kolkata Airport / Kolkata Port/Para deep Port/Visakhapatnam Port.
2. The prices shall be in any freely convertible currency such as Dollar, Pound Sterling, Deutsch Mark, Japanese Yen and Euro only.
3. The prices shall be firm and free from corrections and erasures.
4. The prices shall be valid for 180 days from the date of Bid Opening.
5. Quotation shall be submitted in English Language only.
6. Delivery Period shall be firm and clearly indicated in the Quotation. In case of urgency, early deliveries may be requested.
7. Approximate Dimension of the consignment, Gross and Net weight shall be indicated in the quotation.
8. Packing and Insurance:
 - a. Packing shall be transport worthy to ensure safe delivery considering the nature of the goods.
 - b. Incase insurance shall be arranged by OPGC, the name, address, fax no. and policy no. shall be indicated in the order. Suppliers must send dispatch details by fax/mail to insurance company within 72 hours of handing over the material to carrier.
9. Name and details of foreign advising banker, Country of Origin, Port of Shipment should be indicated in the Quotation.
10. Indian Agency Commission, if any, payable by us shall invariably be included in the CIF Kolkata /Para deep Port/Visakhapatnam Port price. Percentage of Commission shall be clearly mentioned along with the name and address of Indian Agent. A copy of agreement with Indian Agent shall be furnished along with the Quotation.
11. Indian Agency Commission, if any, shall be paid in Indian Rupees only, subject to the following quantum as per Government of India Guidelines:

a. Up to order value Rs. 5,00,000/-	10% (Max)
b. Between Rs. 500000 to Rs. 10,00,000	7.5%
c. Between Rs. 10,00,000 to Rs. 25,00,000-	5%
d. Over Rs. 25,00,000/-	2.5%

(CIF/FOB cost may be converted into equivalent Indian Rupee value and quote IAC subject to above maximum limit)
12. We would prefer to deal directly with the foreign supplier. In case, if our tender enquiry is forwarded to Indian Agent/ Distributor, we shall be informed of the same. The quotation from Indian Agent/ Distributor shall be accepted subject to following:
 - a. The quotation is submitted in accordance with the above instructions along with copy of Agreement with their Principal.
 - b. Quotation submitted by Agent/ Distributor for and on behalf of Principal, be supported with Authority from the Principal / Power Attorney in favour of Indian Agent duly notarized. format enclosed)
 - c. In the event of quotation submitted in Indian Rupees; Principal's price list, applicable Custom duty and Countervailing Duty (if any), with specific reference clauses and base Exchange rate is to be furnished.
 - d. Agent/ Distributor/ Authorised Dealer must be registered with DGS&D/ Govt. of India.
13. Payment Terms:
 - a. Foreign Supplier: 100% of the CIF/FOB/ FCA price less Indian Agent's commission, if any shall be payable through a Irrevocable Letter of Credit against presentation of shipping documents as called for in the purchase order.
 - b. Indian Agent's Commission: 100% agency commission, if any, shall be payable to the Indian Agent in equivalent Indian Rupees at the rate of exchange applicable as on date of Airway Bill/ Bill of Lading within 30 days of shipment of Materials against Invoice



supported by a Certificate indicating exchange rate (TT BUYING), applicable on date of Airway Bill/ Bill of Lading from the Indian Agent's Banker/ Declaration by Central Board of Excise and Customs for the relevant month. In case the date of shipment happens to be Bank Holiday, the exchange rate applicable on the last working day prior to the date of shipment shall be considered.

- c. All bank charges on account of Letter of Credit payable within India shall be borne by OPGC Limited and those outside India are to be borne by the Foreign Supplier.
 - d. The Letter of Credit shall not allow partial shipment or Transshipment normally.
 - e. The arrangement for transportation by Sea/ Air shall be done by the seller as per instructions given in this regard in the Purchase Order.
 - f. The name of carrier chosen to be clearly mentioned. DHL is preferred carrier for OPGCL.
14. Validity of Letter of Credit: The Irrevocable Letter of Credit to be opened through the Purchasers bank shall normally be kept valid for a period of 90 days. The Letter of Credit shall be opened upon intimation from the supplier about the expected date of dispatch of material. Normally extension of the validity of Letter of Credit will not be allowed.
15. Bidder should note that the exchange Rate applicable on the BOD (Bid Opening Date) shall be considered for evaluation purposes.
16. Following Documents are to be submitted while negotiating through L/C:
- a. Invoice/ Airway Bill/ Bill of Lading
 - b. Certificate of Country of Origin Certified by Local Chamber of Commerce.
 - c. Packing List with complete details.
 - d. Inspection/ testing / Guarantee Certificate wherever applicable.
 - e. Copy of confirmation of our insurance company.
 - f. Technical Literature if any
 - g. Psychosanitary certificate for the packing material.

Vendors Signature

Name and address



PROFORMA OF BANK GUARANTEE FOR CONTRACT PERFORMANCE
(On Non-Judicial Stamp paper of Appropriate Value)

1.0 In consideration of OPGC Ltd. Having its registered office at Zone-A, 7th Floor, Fortune Tower, Chandrasekaharpur, Bhubaneswar-751023, Odisha herein-in after called the "Owner" which expression shall unless repugnant to the subject or context include its successor & assignees) having awarded to M/s with its Registered/Head office at..... here-in after referred to as the "Contractor" which expression shall unless repugnant to the subject or context include its successor, executors & assignees) a contract by issue of Owner's Letter of Intent No.....dt. and the same having been unequivocally accepted by the contractor resulting in a contract bearing No.dated valued at Rs.....for and the contractor having agreed to provide a contract performance (Scope of work)

Guarantee for the faithful performance of the entire contract equivalent Rs. 10% (ten percent) of the said value of the contract to the owner for satisfactory performance of the equipment/materials supplied (as detailed in the said agreement) during the Guarantee period (as detailed in the said agreement) and for the due fulfillment by the contractor(s) of the terms and conditions contained in the said agreement.

2.0 We(here-in after referred to as " the bank"
(Name & address of Bank)
having its Head Office atdo hereby guarantee and undertake to pay the owner, on demand any and all amount payable by the contractor not exceeding Rs.(Rupees) only as aforesaid at any time upto
(Days/month/year)

3.0 We do hereby
(Name of Bank)
Undertake to pay the amounts due to and payable under this guarantee without any demur, reservation, contest, recourse or protest and/or without any reference to the contractor. Any such demand made by the owner on the Bank shall be conclusive and binding notwithstanding any difference between the owner and contractor or any dispute pending before any court, tribunal or any other authority. The bank undertakes not to revoke this guarantee during the currency without previous consent of the Owner and further agrees that the guarantee herein contained shall continue to be enforceable till the owner discharges this guarantee.

The payment so made by us under this bond shall be a valid discharge of our liability for payment there under and the contractor(s)/suppliers shall have no claim against us for making such payment.

4.0 We further agree that the
(Name of Bank)
guarantee herein contained shall remain in full force and effect during the period that would be taken for the performance of the said Agreement and that it shall continue to be enforceable till all dues of OPGC have been fully paid and its claims satisfied or discharged until OPGC certifies that the terms & conditions of the said Agreement have been fully and properly carried out by the said contractor(s) and accordingly discharges this guarantee.

5.0 We further agree with the
(Name of Bank)



OPGC that OPGC have the fullest liberty without our consent and without affecting in any manner our obligations hereunder to vary any of the terms and conditions of the said agreement or to extend time of performance by the said contractor(s) from time to time or to postpone for any time or from time to time any of the powers exercisable by the OPGC against the said contractor(s) and to for bear or enforce any of the terms and conditions relating to the said agreement and we shall not be relieved from our liability by reason of any such variation, postponement or extension being granted to the said contractor(s) or for any forbearance, act or omission on the part of the OPGC or any indulgence by the OPGC to the said contractor(s) or by any such matter or thing whatsoever which under the law relating to sureties would but for this provision have effect of so relieving us.

6.0 This guarantee will not be discharged due to the change in the name, style and constitution of the Bank or the contractor(s)/suppliers(s).

7.0 Notwithstanding anything contained herein a)Our liability under this bank guarantee shall not exceed Rs..... [Rupees] b) This bank guarantee shall be valid uptoc) We are liable to pay the guaranteed amount or any part thereof under this B.G only and only if the beneficiary/Govt. serves upon the bank a written claim or demand on or before

8.0 Welastly undertake not to revoke this
(Name of Bank)
Guarantee during its currency except with the previous consent of the OPGC in writing.
Dated theday of200...

9.0 Notwithstanding anything contained hereinabove our liability under this guarantee is restricted to Rs.....(Rupees.....only) and this guarantee is valid upto We shall be released and discharged from all liabilities hereunder unless a written claim for payment under this guarantee is lodged on us within three months from the date of expiry of the guarantee i.e on or before Irrespective of whether or not the original guarantee is returned to us.
The confirmation of this Bank Guarantee is available within our controlling office. The beneficiary in his own interest should obtain such confirmation from the controlling office at the following address

WITNESS with address

1.
2.

For and on behalf of (the Bank)

Signature
Name
Designation
Authorisation No.
Seal of the Bank



PROFORMA FOR BANK GUARANTEE IN LIEU OF DD FOR EARNEST MONEY

(On Non Judicial stamp paper of appropriate value)

Ref:

Date:

Bank Guarantee No.

To
Odisha Power Generation Corporation Ltd.,
IB Thermal Power Station,
At/Po- Banharpali,
Dist-Jharsuguda-768234.

Dear Sir,

In consideration of Odisha Power Generation Corporation having its Registered office at 7th Floor, Zone – A, Fortune Towers, Chandrasekharpur, Bhubaneswar-751 023 (hereinafter called the "Owner" which expression shall unless repugnant to the subject or context include its successors and assigns) having issued Tender Specification Against NIT No _____ dt. _____ to M/s _____ having its Registered / Head office at _____ (hereinafter called the Bidder) who wishes to participate in the said tender for and you, as a special favour, have agreed to accept an irrevocable and unconditional Bank Bid Guarantee for an amount of Rs. _____ valid up to _____. On behalf of the Bidder, as a condition for participation in the said tender.

We, the _____ Bank incorporated under _____ law and having one of our branches at _____ and having our Registered office/Head office at _____ do here by unconditionally and irrevocably guarantee and under take to pay to the " Owner" immediately on demand without any demur reservation, protest, contest and recourse to the extent of the said sum of Rs. _____ (Rupees _____ only). Any such claim/demand made by the said "Owner" on us shall be conclusive and binding on us irrespective of any dispute or differences raised by the Bidder.

This guarantee shall be irrevocable and shall remain valid up to _____. If any further extension of this guarantee is required, the same shall be extended to such required period on receiving instructions from M/s _____ on whose behalf this guarantee is issued.

We, the said Bank lastly undertake not to revoke this guarantee during its currency except with the previous consent of the owner in writing and agree that any change in the constitution of the said tenderer or the said Bank shall not discharge our liability. In witness where of the Bank, through its authorised officer, has set its hand and stamp on this _____ day of _____ 20_____

Witness:

(Signature)

(Signature)

Name

Name

Official Address

(Designation with Bank stamp)

Attorney as per Power of Attorney
No. _____ & Date: _____



**Bank MANDATE FORM for e-payment
(To be submitted in Duplicate)**

To.
M/s Odisha Power Generation Corporation Ltd.,
IB thermal power station,
Banharpali, Odisha

Dear Sir,

Sub :- Authorization for release of payment due from OPGC Ltd through e-mode facilities of RTGS / NEFT / Internet Banking.

We are the regular contractor/Supplier to your organization and are executing work /supplying materials under different Contracts/ Purchase Orders to OPGC Ltd. We request you to release the payment of the outstanding amount electronically i.e, through RTGS, NEFT, Fund Transfer or any other suitable way. The details of our bank account are as follows: -

(Please fill in the information in CAPITAL LETTERS. Please TICK wherever it is applicable)

1. Name of the Party:

2. Address of the Party
.....

City Pin Code

E-mail ID

Permanent Account Number

Telephone/Cell No.....

3. Particulars of Bank :

Bank Name		Branch Name	
Branch Place		Branch City	
Pin code		Branch Code	
MICR No			
Account Type	Savings:	Current:	Cash Credit:
Account No. (as appearing in the Cheque Book) :			
(9 Digits code number appearing on the MICR Bank of the cheque supplied by the Bank. Please attach Photo copy of a cheque of your bank for ensuring accuracy of the bank name, branch name & code and Account number)			
IFSC Code			

4. Date from which the mandate should be effective :

I hereby declare that the particulars given above are correct and complete. If any transaction is delayed or not effected for reasons of incomplete or incorrect information, I shall not hold Odisha Power Generation Corporation Ltd responsible. I also undertake to advise any change in the particulars of my account to facilitate up dation of records for purpose of credit of amount through internet / RTGS / NEFT.

Place:

Date :

Signature of the Party / Authorized Signatory

.....
Certified that particulars furnished above are correct as per our records.

Bank's Stamp:

Date:

(Signature of the Authorized Official from the Banks)



INTEGRITY PACT

Between

Odisha Power Generation Corporation Ltd. (OPGC), a company registered under the Companies Act 1956 and having its registered office at Zone-A, 7th Floor, Fortune Towers, Chandrasekharpur, Bhubaneswar-751023, Odisha (India) hereinafter referred to as "Principal", which expression unless repugnant to the context or meaning hereof shall include its successors or assigns of the ONE PART

And

_____, description of the party along with address), hereinafter referred to as "Bidder/ Contractor" which expression unless repugnant to the context or meaning hereof shall include its successors or assigns of the OTHER PART

(The Principal and the Bidder/ Contractor together are collectively referred to as the "Parties" and individually as a "Party" in this Pact).

Preamble

The Principal intends to award, under laid-down organizational procedures, contract/s for... ("Contract") The Principal values full compliance with all relevant laws of the land, rules and regulations, and the principles of economic use of resources, and of fairness and transparency in its relations with its Bidder(s)/ Contractor(s).

In order to achieve these goals, the Principal enter into an Integrity Pact ("Pact") with the Bidder(s)/ Contractor(s) for the tender process and execution of the Contract and will appoint Independent External Monitor(s), who will monitor the tender process and the execution of the Contract for compliance with the principles mentioned above.

Section 1 – Commitments of the Principal

1.1 The Principal commits itself to take all measures necessary to prevent corruption and to observe the following principles:-

1.1.1 No employee/Director/management representative of the Principal, personally or through family members or through third party, will in connection with the tender process for, or the execution of a Contract, demand, take a promise for or accept, for self or third person, any material or immaterial benefit which the person is not legally entitled to.

1.1.2 The Principal will, during the tender process treat all Bidder(s)/ Contractor(s) with equity and reason. The Principal will in particular, before and during the tender process, provide to all Bidder(s) the same information (other than the clarifications sought for by the Bidder(s)/Contractors with respect to the bidder specific information required to be provided only to the concerned Bidder(s)/Contractor(s),) and will not provide to any Bidder(s)/Contractor(s) confidential / additional information through which the Bidder(s) /Contractor(s) could obtain an advantage in relation to the tender process or the contract execution.

1.1.3 The Principal will exclude from the tender process or execution of the Contract all known prejudiced persons including those employees/ Directors/management representatives of the Principal who have family relationships with the employees or Directors of the Bidder(s)/Contractor(s).

1.2 If the Principal obtains information on the conduct of any of its employees/ Directors/ management representative which is a penal offence under the Indian Penal Code 1860 and Prevention of Corruption Act 1988 or any other statutory penal enactment, or if there be a substantive suspicion in this regard, the Principal will inform its Chief Vigilance Officer for further enquiry and initiation of disciplinary actions against the person(s) concerned.

Section 2 – Commitments of the Bidder(s)/ Contractor(s)

2.1 The Bidder(s)/ Contractor(s) commit itself to take all measures necessary to prevent corruption. The Bidder(s) / Contractor(s) commits itself to observe the following principles during its participation in the tender process and during the contract execution.

2.1.1 The Bidder(s)/ Contractor(s) will not, directly or through any other person or firm, offer, promise or give to the Principal or to any of the Principal's employees/ Directors/ management representative involved in the tender process or the execution of the Contract or to any third person any material, immaterial or any other benefit which he / she is not legally entitled to, in order to obtain in exchange any advantage of any kind whatsoever during the tender process or during the execution of the Contract.

2.1.2 The Bidder(s)/ Contractor(s) will not enter with other Bidder(s) into any illegal or undisclosed agreement or understanding, whether formal or informal. This applies in particular to prices, specifications, certifications, subsidiary contracts, submission or non-submission of bids or any other actions to restrict competitiveness or to introduce cartelization in the bidding process.

2.1.3 The Bidder(s)/ Contractor(s) will not commit any penal offence under the relevant IPC/ PC Act and any other such similar applicable Acts; further the Bidder(s)/ Contractor(s) will not use improperly, for purposes of competition or personal gain, or pass on to others, any information or document provided by the Principal as part of the business relationship, regarding plans, technical proposals and business details, including information contained or transmitted electronically.

2.1.4 The Bidder(s)/ Contractor(s) will, when presenting his bid, disclose any and all payments he has made, and is committed to or intends to make to agents, brokers or any other intermediaries in connection with the award of the contract.

2.1.5 The Bidder(s) / Contractor(s) will not, directly or through any other person or firm, approach any Government officials, ministers, political persons public servants, or any external agencies in an effort to influence the bidding decision making process or to attain any undue favours to the Bidder(s) / Contractors(s).

2.1.6 The Bidder(s)/Contractor(s) shall exclude, from the tender process or execution of the Contract all known prejudiced persons including those employees / Directors /management representatives of the Bidder(s) / Contractor(s) who have family relationships with the employees or Directors of the Principal.

2.1.7 The Bidder(s)/Contractor(s) shall disclose the circumstances, arrangements, undertakings or relationships that constitute, or may reasonably be considered to constitute, an actual or potential conflict of interest with its obligations specified in the tender process or under any contract which may be negotiated or executed with the Principal. Bidder(s)/Contractor(s) and their employees, agents, advisors and any other person associated with the Bidder(s)/Contractor(s) must not place themselves in a position which may, or does, give rise to conflict of interest (or a potential conflict of interest) between the interests of the Principal or any other interests during the tender process or through operation of the Contract.

2.1.8 The Bidder(s)/Contractor(s) will not indulge in any corrupt, fraudulent, coercive undesirable or restrictive practice in the tender process or the execution of the Contract.

2.2 The Bidder(s)/ Contractor(s) or its sub contractors or its agents will not instigate third persons to commit offences outlined above or be an accessory to such offences.

Section 3 – Disqualification from tender process, termination of the Contract and exclusion from future contracts

If the Bidder(s)/ Contractor(s), during the tender process or before award of the Contract or during the execution of the Contract has committed a transgression through a violation of Section 2 above, or acts in any other manner such as to put its reliability or credibility in question, the Principal may disqualify the Bidders(s)/ Contractor(s) from the tender process or decide not to award the Contract or terminate the awarded Contract or blacklist the Bidder(s)/Contractor(s). I and seek damages as specified in

Section 4 – Compensation for Violations

4.1 If the Principal has disqualified the Bidder(s)/ Contractor(s) from the tender process prior to the award of the Contract according to Section 3 or 5, the Principal is entitled to demand and recover the damages by encashment of the Earnest Money Deposit/ Bid Security deposited by the Bidder(s)/ Contractor(s) while making submission in the tender process.

4.2 If the Principal has terminated the Contract according to Section 3 or 5, or if the Principal is entitled to terminate the Contract according to section 3 or 5, the Principal is entitled to demand and recover from the Contractor liquidated damages equivalent to 5% of the Contract value or the amount equivalent to Security Deposit/Performance Bank Guarantee, whichever is higher, in addition to the Liquidated Damages already agreed to by the Bidder(s)/ Contractor(s) in the Contract..

Section 5 – Previous Transgression

5.1 The Bidder(s)/ Contractor(s) declares that no previous transgressions occurred in the last three (3) years with any other organization in any country conforming to the anti-corruption approach or with any other Public Sector Enterprise in India that could justify its exclusion from the tender process or the execution of the Contract.

5.2 If the Bidder/ Contractor has made incorrect statement/disclosure on this subject or hides such information, the Principal is entitled to disqualify the Bidder/Contractor from the tender process or the execution of the Contract, if already awarded, may terminate the Contract and claim compensation as mentioned in section 4.

Section 6 – Equal treatment of all Bidders/ Contractors/ Sub-contractors

6.1 The Bidder(s)/ Contractor(s) undertake(s) to demand from his sub-contractors a commitment consistent with this Integrity Pact. This commitment shall be taken only from those sub-contractors whose contract value is more than 20% of Bidder's/ Contractor's contract value with the Principal.

6.2 The Principal will enter into individual Integrity Pacts with identical conditions as this one with all Bidders and Contractors for the tender process.

6.3 Only those Bidder(s)/ Contractor(s) who have entered or expressed intention of entering into Integrity Pact with the Principal shall be eligible to participate in the tender process or execution of the Contract.

6.4 The Principal will disqualify the Bidder(s)/ Contractor(s) from the tender process who do not execute the Integrity Pact or violate its provisions.

Section 7 – Criminal Charges against violating Bidders/ Contractors/ Subcontractors

If the Principal obtains knowledge of conduct of a Bidder, Contractor or Subcontractor, or of an employee or a representative or an associate of a Bidder, Contractor or Subcontractor which constitutes corruption, or if the Principal has substantive suspicion in this regard, the Principal will inform the Vigilance Office of the State in which the Principal has its Registered Office.

Section 8 –Independent External Monitor(s)

8.1 The Principal will appoint one or more competent and credible Independent External Monitor(s) ("**Monitor**") for monitoring the implementation of this Pact. The task of the Monitor will be to review independently and objectively, whether and to what extent the Parties comply with the obligations of the Integrity Pact.

8.2 The Monitor shall not be subject to instructions by the representatives of the Parties and shall perform his functions neutrally and independently. The Monitor shall report to the OPGC Board.

8.3 The Bidder(s)/ Contractor(s) accepts that the Monitor has the right to access without restriction to all the document related to the tender process or the execution of the Contract of the Principal including that provided by the Bidder(s)/ Contractor(s). The Bidder(s)/ Contractor(s) shall grant the Monitor, upon his request and demonstration of a valid interest, unrestricted and unconditional access to the document in its possession related to the tender process or execution of the Contract. The same is applicable to Sub-contractor(s) of the Bidder(s)/ Contractor(s). The Monitor is under contractual obligation to treat the information and documents of the Bidder(s)/ Contractor(s) / Subcontractor(s) with strict confidentiality.

8.4 The Principal will provide to the Monitor sufficient information about all meetings among the Parties related to the tender process or the execution of the Contract provided such meetings could have



an impact on the contractual relations between the Principal and the Bidder/ Contractor. The Parties shall offer to the Monitor the option to participate in such meetings.

8.5 As soon as the Monitor notices, or believes to have noticed, a violation of the Integrity Pact, he will so inform the Managing Director of the Principal and request him to take corrective action, or heal the situation, or to take other relevant action. The Monitor may in this regard submit non-binding recommendations. Beyond these actions, the Monitor shall have no right to demand from the Parties that they act in a specific manner, refrain from action or tolerate action.

8.6 If the Monitor reports to the Managing Director of the Principal, a substantiated suspicion of an offence under relevant IPC / PC Act, the Managing Director of the Principal shall within reasonable time, taken visible action to proceed against such offence.

8.7 The number of Independent External Monitor(s) shall be decided by OPGC.

8.8 The word 'Monitor' would include both singular and plural.

Section 9 – Pact Duration

9.1 This Pact shall become effective from the date when both the Parties have executed it or the Parties have shown their intent to enter into the Pact, whichever is earlier. This Pact will expire for the Contractor after it meets all the obligations of the Contract and for all other Bidders 6 months after the Contract has been awarded.

9.2 If any claim is made / lodged during this time, the same shall be binding and continue to be valid despite the lapse of this Pact as specified as above, unless it is discharged/ determined by the Principal

Section 10 – Other Provisions

10.1 This agreement is subject to Indian Laws and jurisdiction shall be registered office of the Principal, i.e. Bhubaneswar.

10.2 Changes and supplements to the Pact as well as notices of termination of the Pact to be sent to any Party shall be made in writing by mutual agreement between the Parties.

10.3 If the Bidder/ Contractor is a partnership or a consortium, this Pact shall be signed by all partners or consortium members.

10.4 Should one or several provisions of this agreement turn out to be invalid, the remainder of this agreement remains valid. In this case, the parties will strive to come to an agreement to their original intentions.

10.5 Only those Bidder(s)/ Contractor(s) who have expressed their intention through submission in the tender process or have entered into this Pact with the Principal will be eligible to participate in the bidding.

For & On behalf of the Principal For & On behalf of the Bidder/ Contractor

(Office Seal)

(Office Seal)

Place-----

Date-----

Witness: _____

Witness: _____

(Name & Address) _____

(Name & Address) _____

ANNEXURE-I [Linner-1]

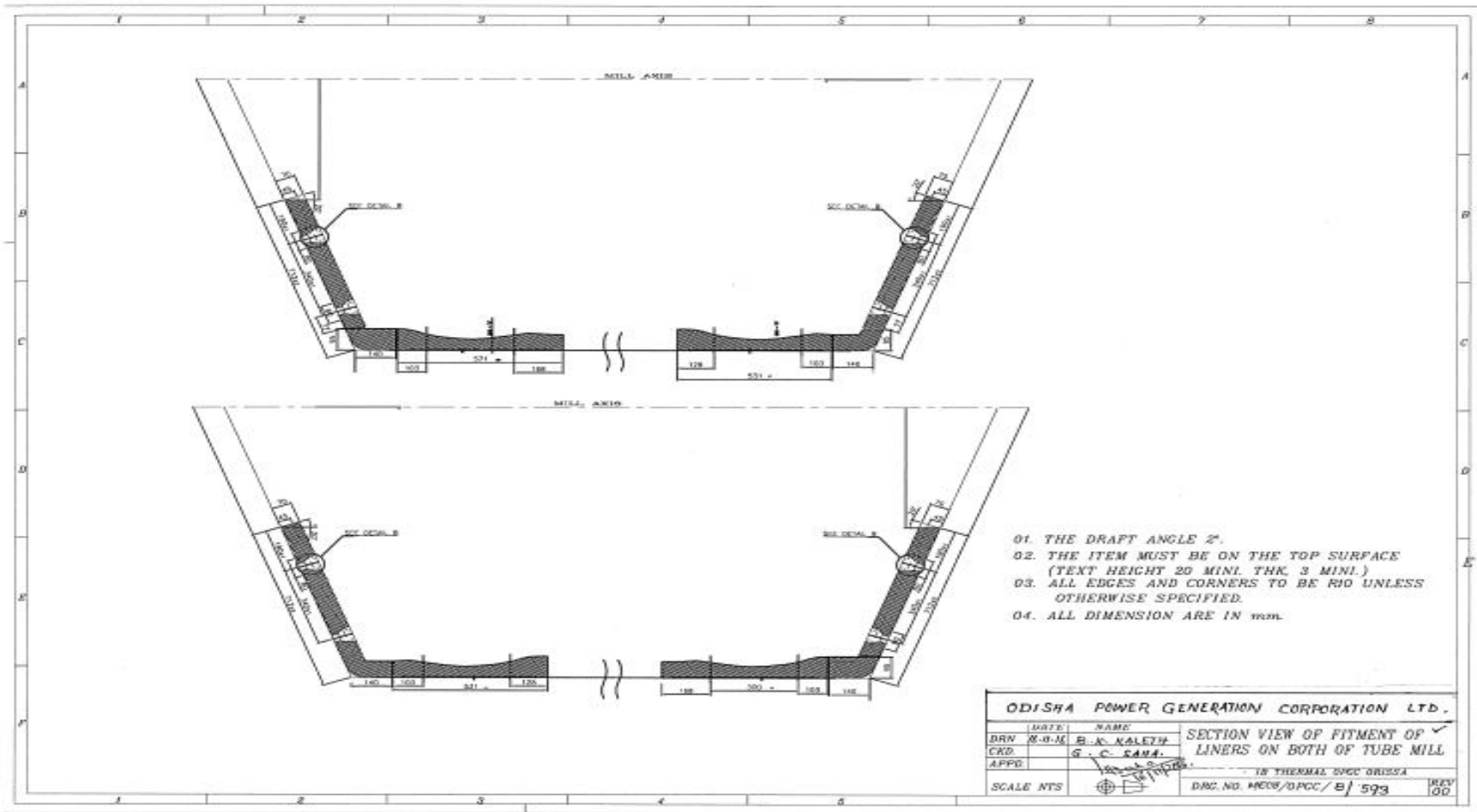

ANNEXURE-II [Liner-2]

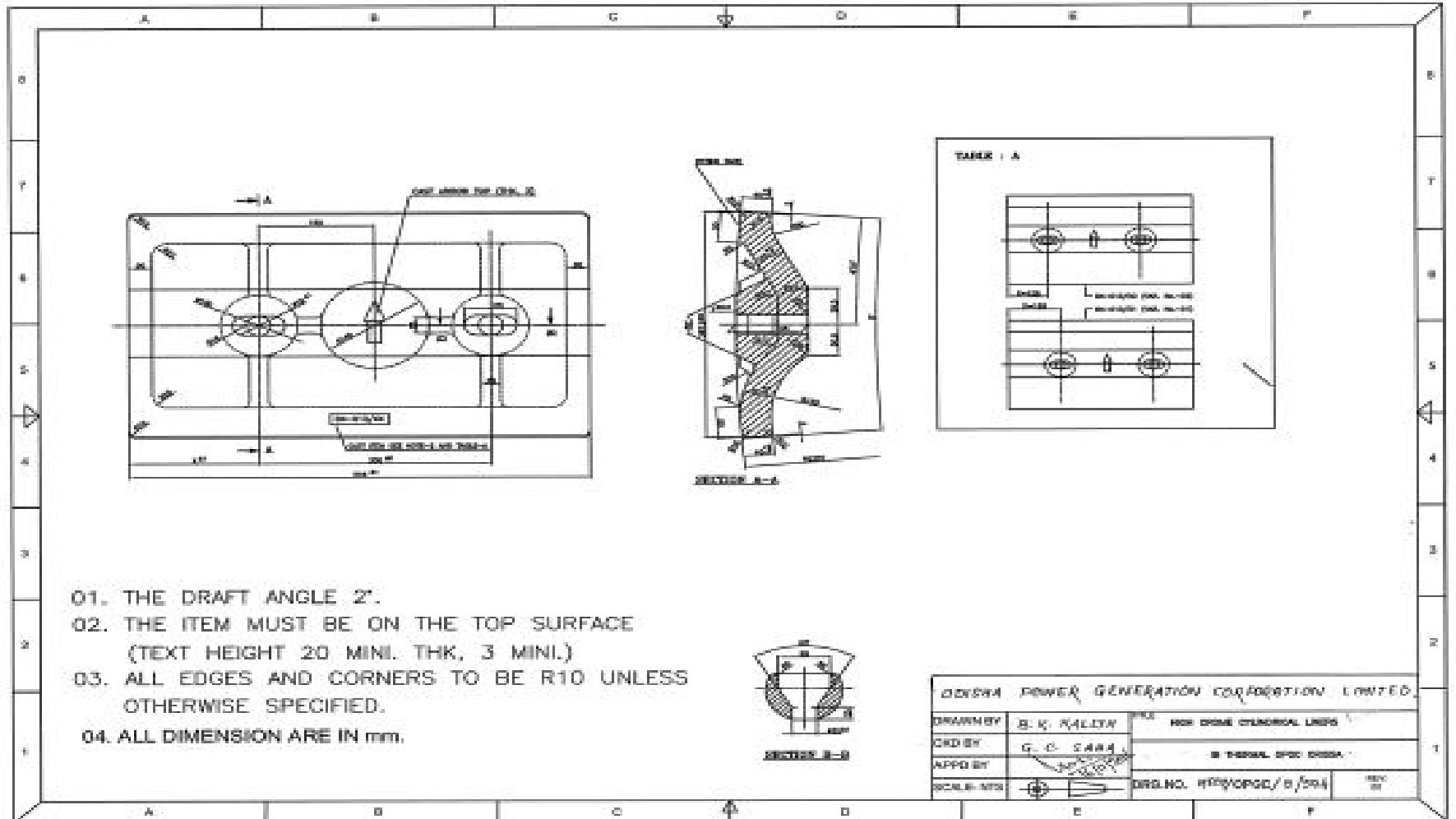

ANNEXURE-III [Liner-3]

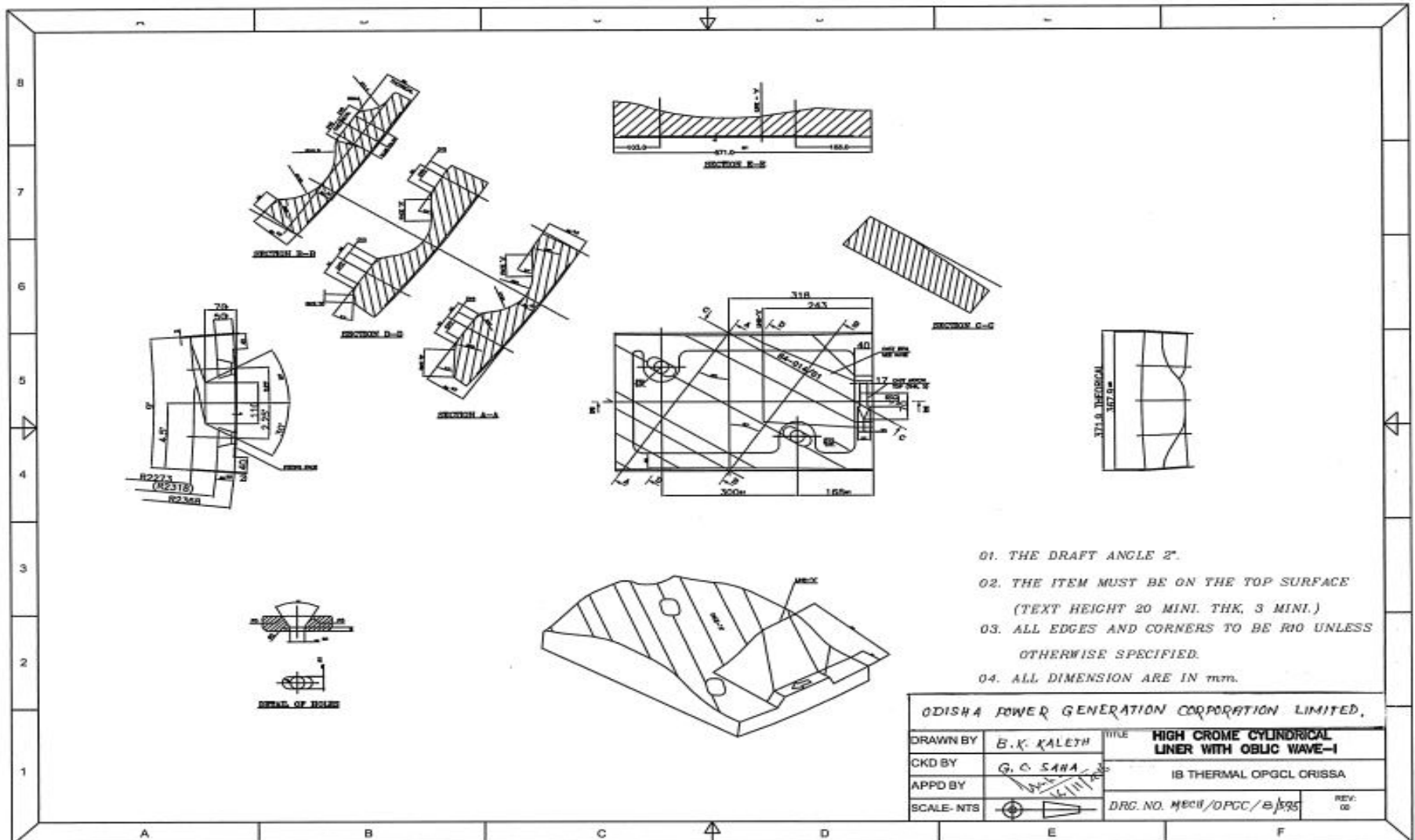

ANNEXURE-IV [Liner-4]

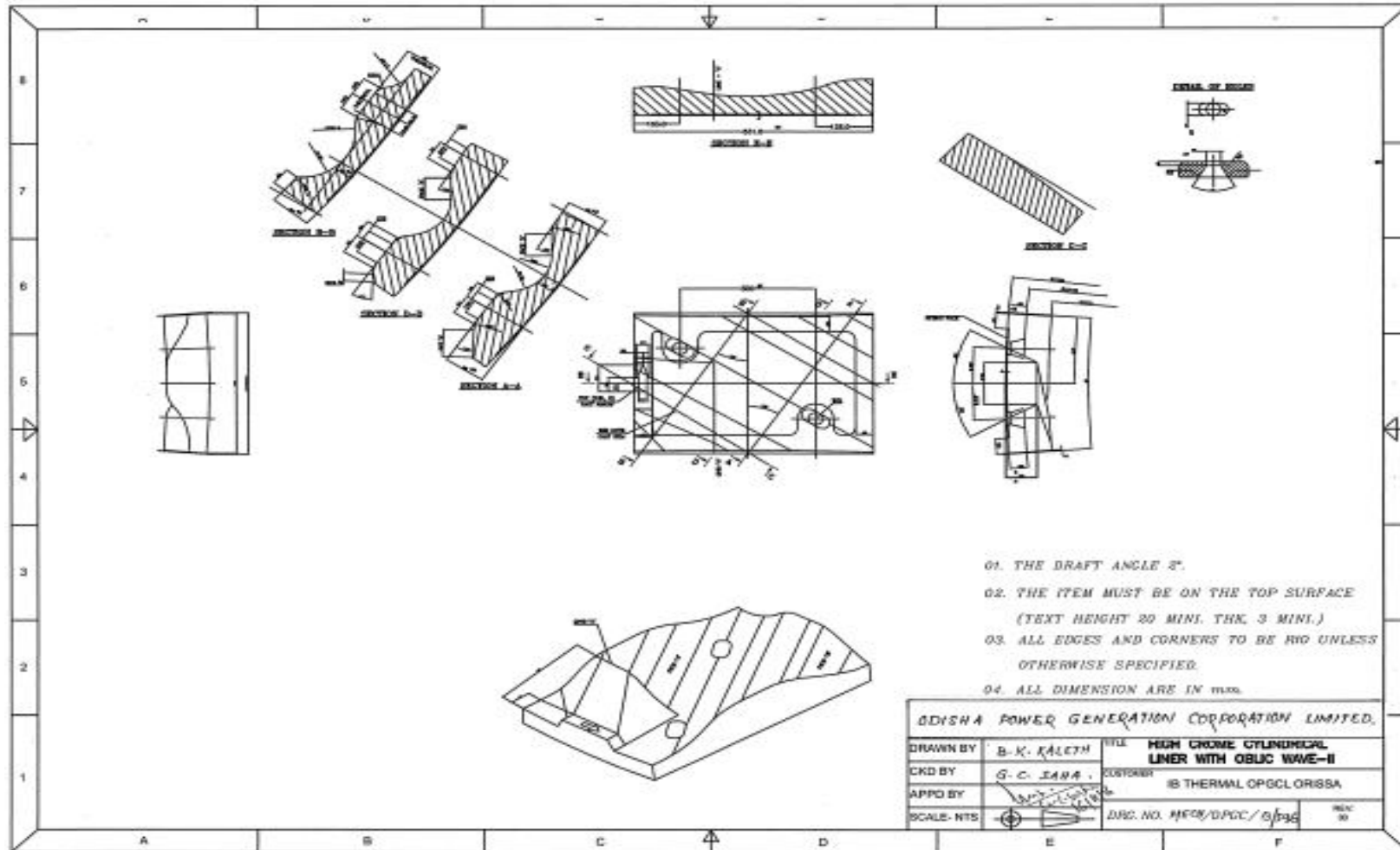

ANNEXURE-V [Liner-5]

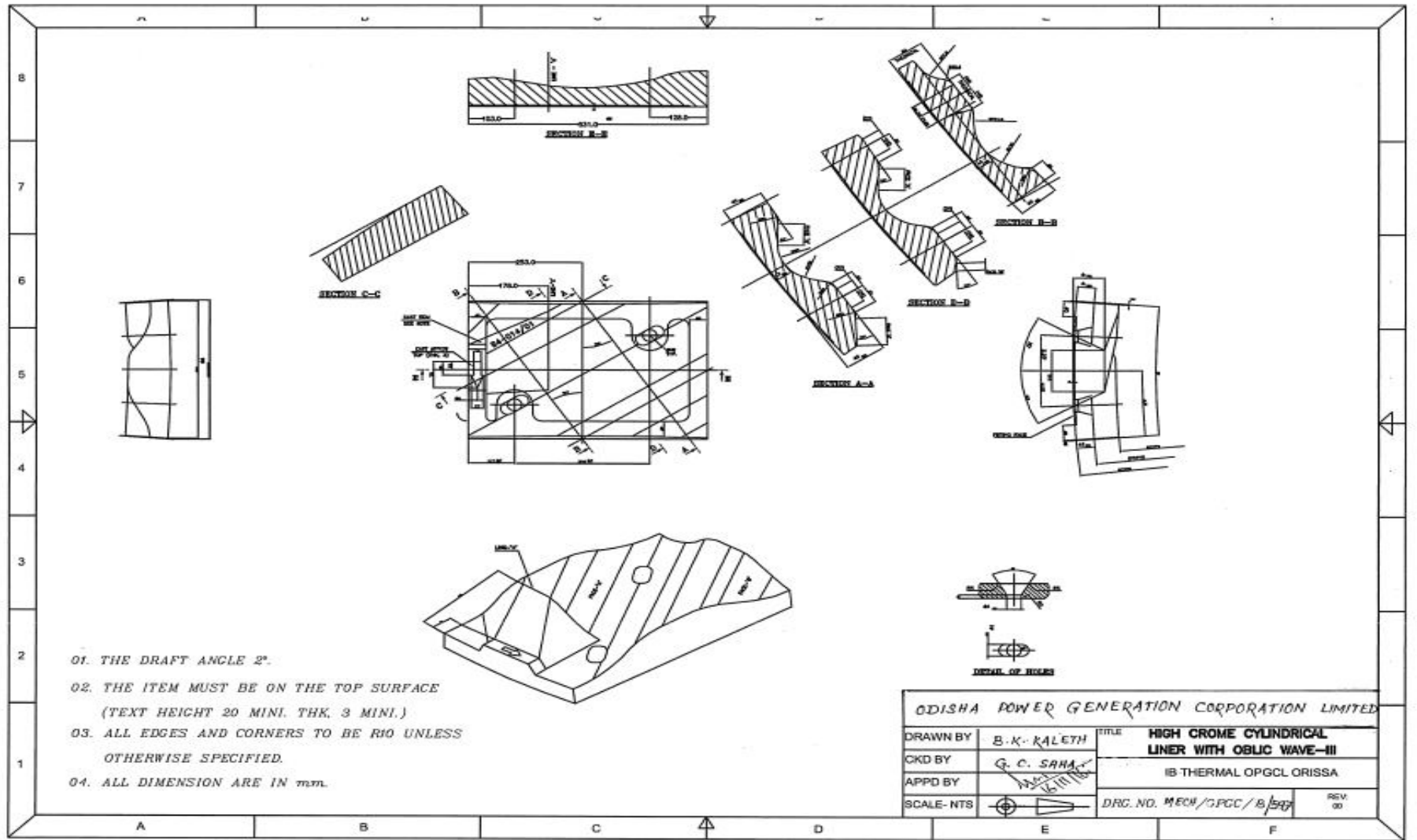

ANNEXURE-VI [Liner-6]

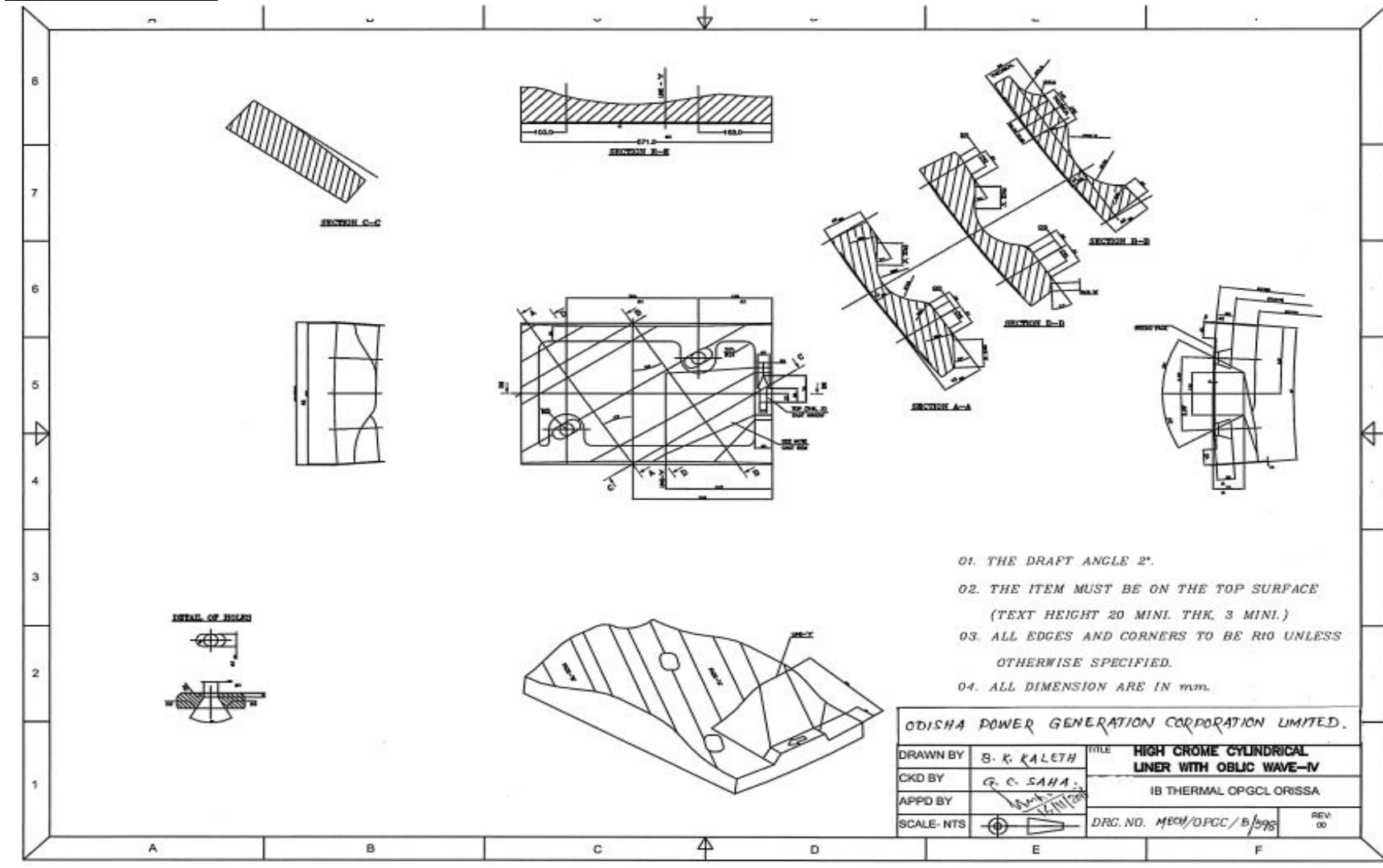

ANNEXURE-VII [Liner-7]

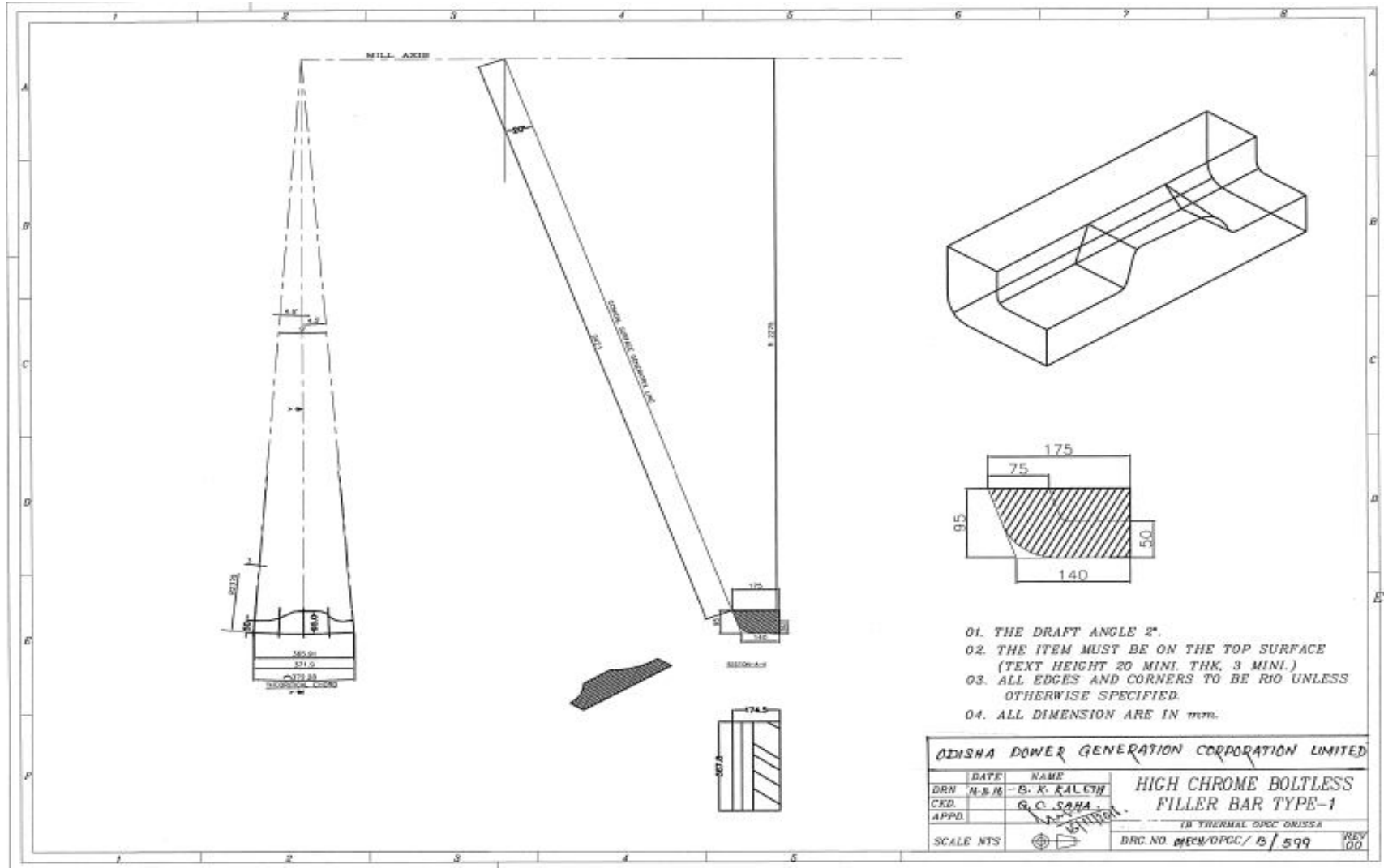

ANNEXURE-VIII [Annexure-8]

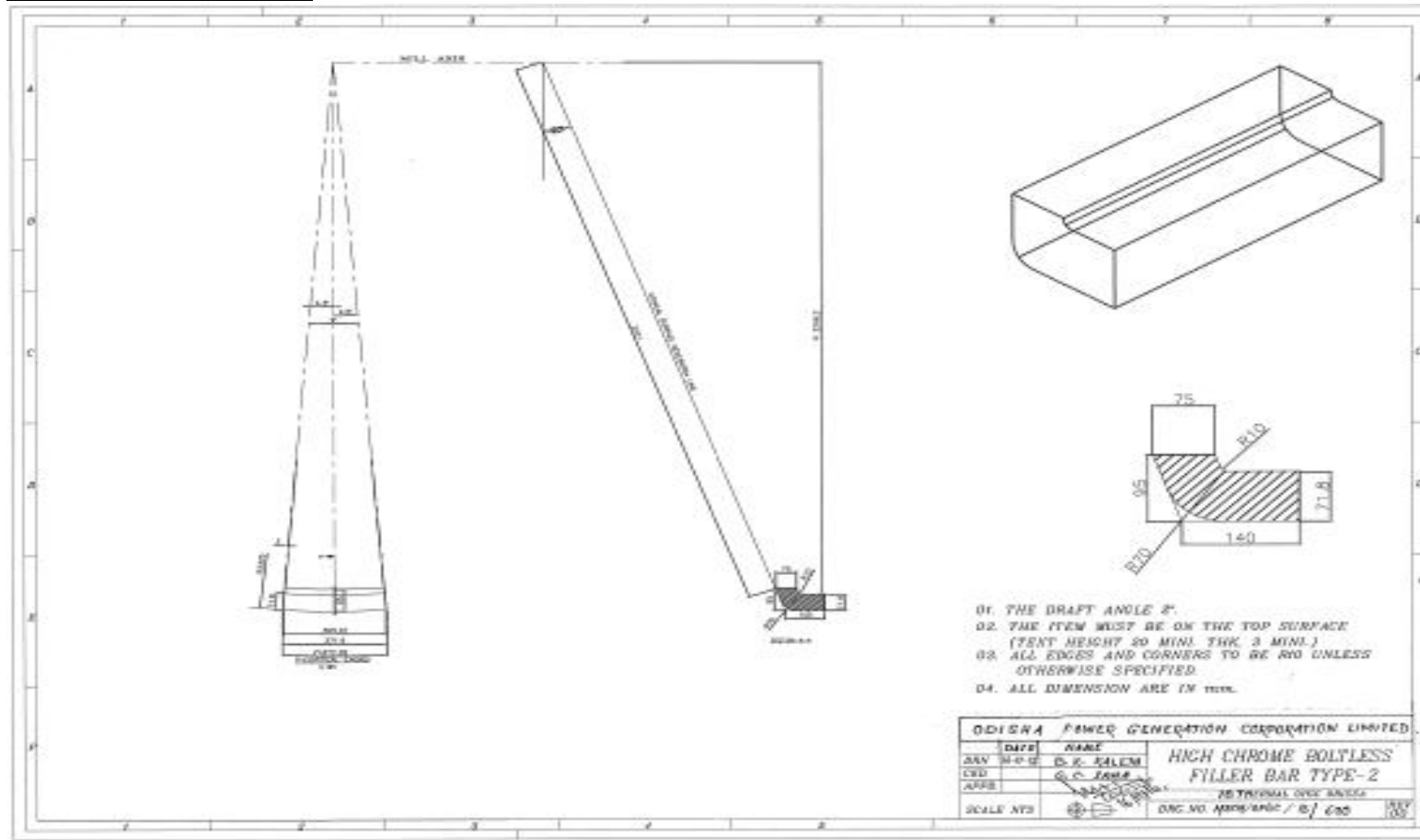

01. THE DRAFT ANGLE ϕ .
02. THE ITEM MUST BE ON THE TOP SURFACE (75% HEIGHT SO MIN. THK. 3 MIN.)
03. ALL EDGES AND CORNERS TO BE RND UNLESS OTHERWISE SPECIFIED.
04. ALL DIMENSION ARE IN mm.

ODISHA POWER GENERATION CORPORATION LIMITED	
DATE	NAME
REV. NO. 01	D. K. SALEM
DESIGN	D. C. JANA
SCALE	AS SHOWN
SCALE 1:2	DATE 10/10/16
HIGH CHROME BOLTLESS FILLER BAR TYPE-2	
ASTM A213 / ASME SA213	
Dwg. No. MPGE/MPGC / 01 / 001	

ANNEXUR-IX [Liner-9]

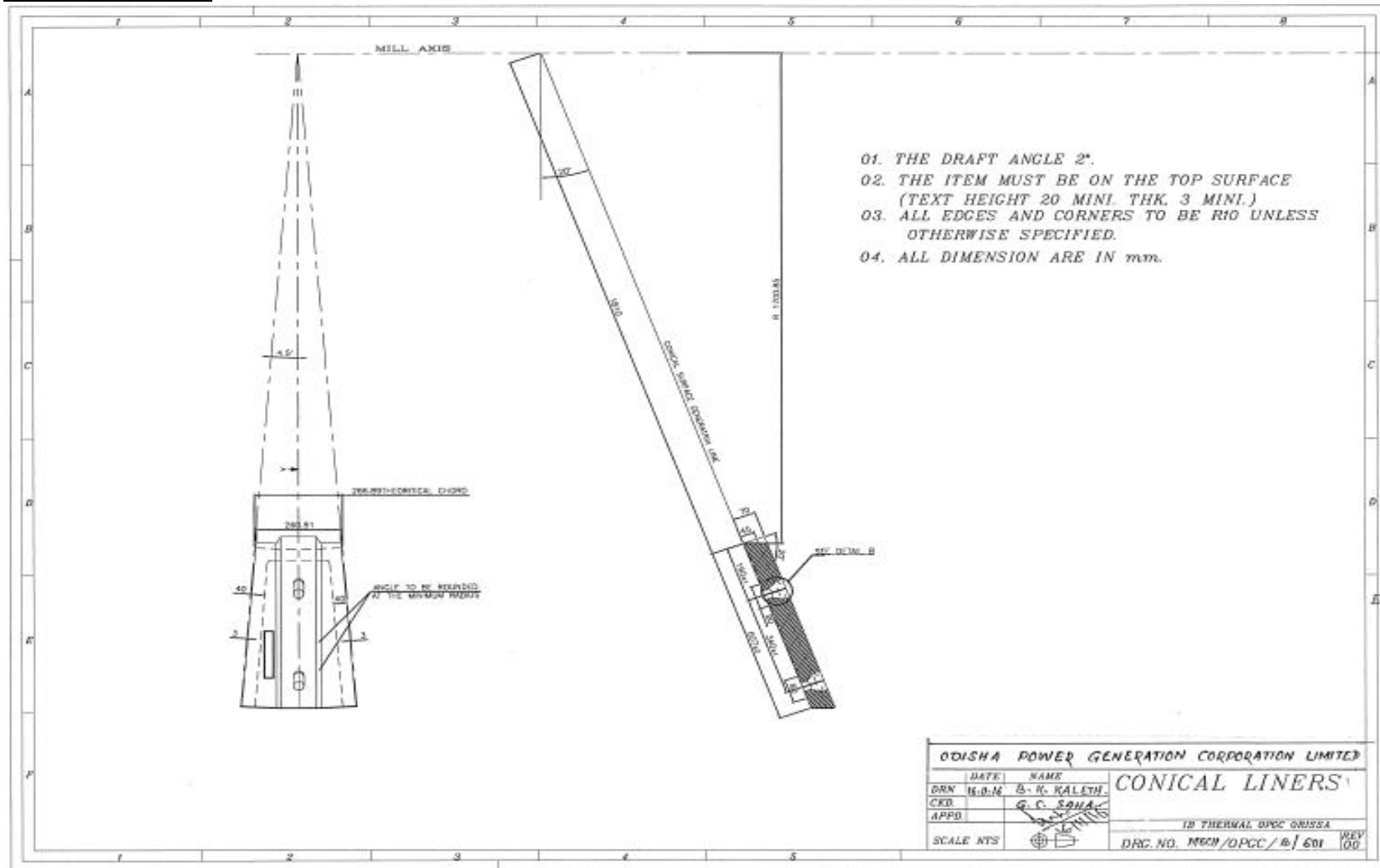

ANNEXURE-X [Liner-10]

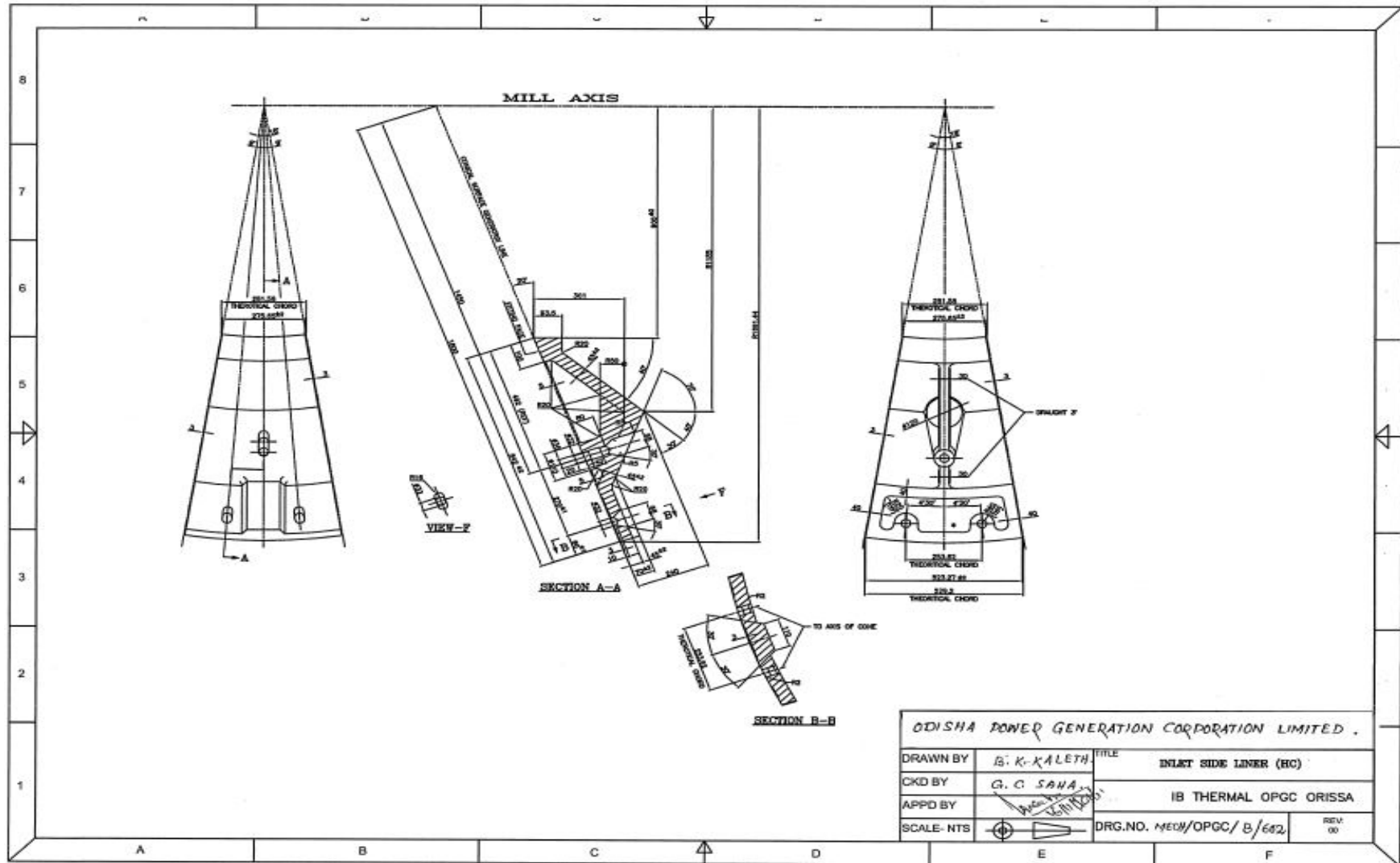

ANNEXURE-XI [Liner-11]

