



# Odisha Power Generation Corporation Limited IB Thermal Power Station

AT/P.O: BANHARPALI,; DIST.: JHARSUGUDA, PIN:768234(ODISHA), INDIA

Tel. 06645-289354 / 289355 / 289356, Fax: 06645- 289355.  
E mail: [bn.das@opgc.co.in](mailto:bn.das@opgc.co.in); [bkmishra@opgc.co.in](mailto:bkmishra@opgc.co.in); [purchase@opgc.co.in](mailto:purchase@opgc.co.in);

SAFE & CLEAN POWER IS OUR COMMITMENT

AN ISO-14001; OHSAS-18001 ORGANIZATION

Tender documents against  
NIT No. ITPS/ (Purchase)/2018-2019/11(P) dt.05/05/2018  
for supply of different size half round sleeves, U clamp & screen tube box to  
IB Thermal Power Station.

Date for Issue of Tender Paper	01/06/2018 to 16/06/2018
Last Date of receipt of Bid	18/06/2018 up to 15.00 hrs. at our office
Date of Tender Opening	18/06/2018 at 15.30 hrs
Cost of Tender Paper	Free of cost from the under mentioned office. May be downloaded from our website.
Earnest Money Deposit	Rs 16,000/- (Sixteen thousand only)

Note: Before Submission of bid please ensure proper documentation is made as mentioned in the bid.

AGM (SCM)

Issued to M/s .....

.....

.....

NIT No.- ITPS/ (Purchase)/2018-2019/11(P) dt.05/05/2018

Odisha Power Generation Corporation Limited (an ISO-14001:OSHAS-18001 and a leading dividend paying company in the state of Odisha) invites sealed tender in an envelope super scribing the tender No. from bonafide manufacturers/Authorised stockiest/dealers/distributor only for supply of following items to 2 x 210 MW Ib. Thermal Power Station.

**(A) SPECIFICATION:**

Half round sleeve, screen tube box sleeve & U clamps of different specification a given below shall be supplied.

Sl. No.	Item Description	Size & MOC	Qty. In no
1	Half Round Sleeve (As per drawing)	ID x L x Thick: 77x500x3mm, MOC SS, Grade - 309	400
2	Half Round Sleeve (As per drawing)	ID x L x Thick: 55x500x3mm, MOC SS, Grade - 309	400
3	Half Round Sleeve (As per drawing)	ID x L x Thick: 45x500x3mm, MOC SS, Grade - 309	2000
4	Screen Tube Box Sleeve (As per drawing)	Size ID x Width x Length x Thick: 78x180x500x3 mm, MOC SS, Grade - 309	500
5	U Clamp (As per drawing)	For pipe OD – 76.1 mm, ID x L x Thick: 80x30x3mm, MOC SS, Grade - 309	800
6	U Clamp (As per drawing)	For pipe OD – 45 mm, ID x L x Thick: 50x30x3mm, MOC SS, Grade - 309	3000

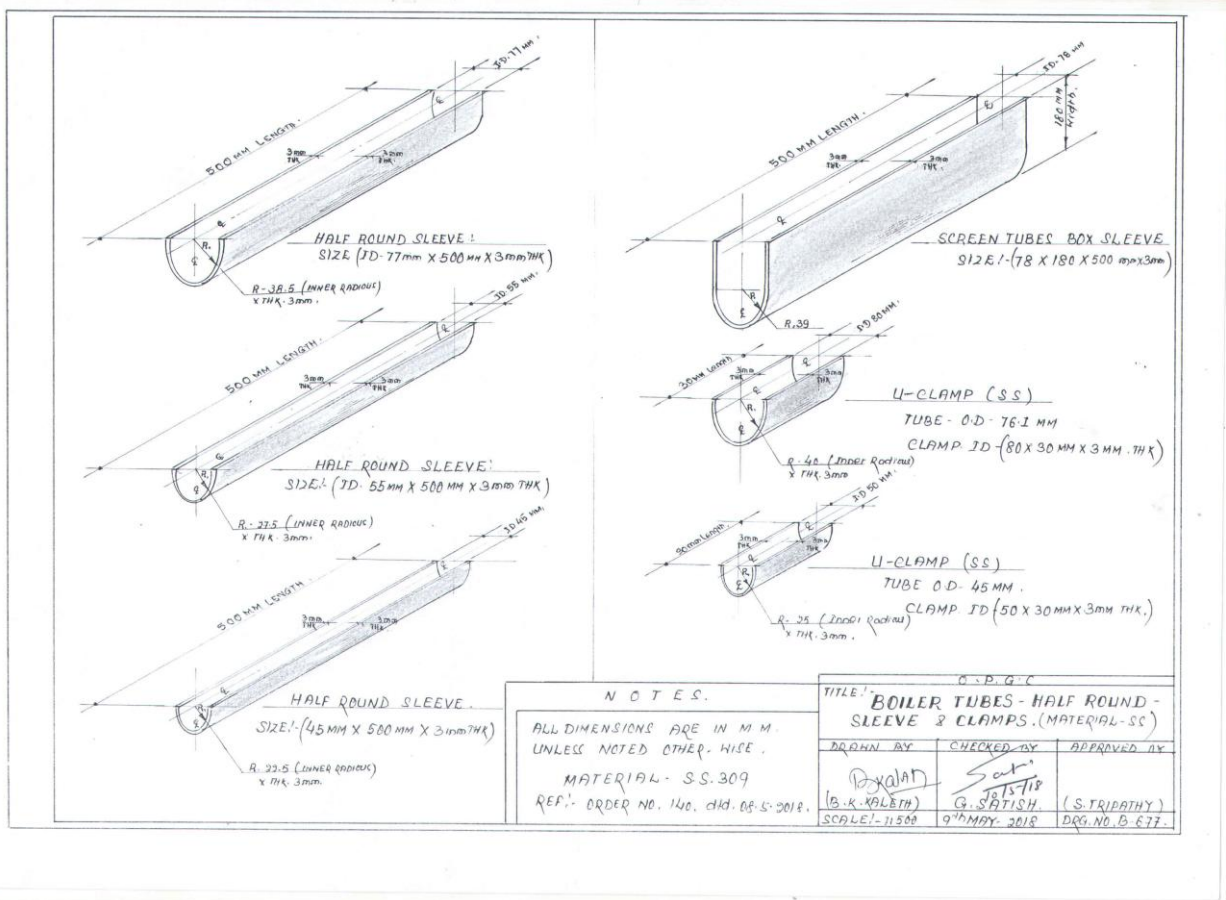



# Odisha Power Generation Corporation Limited

## IB Thermal Power Station

### **(B) Terms & Conditions of Supply**

01. Quality: The material to be supplied should be new, free from all flaws, good finish and should be as per technical specification.
02. Quantity: The quantity indicated is provisional and subject to change at the time of order.
03. Price: The net price offered shall be on the basis of delivery F.O.R, Ib Thermal Power Station site (our site). Packing, forwarding, freight & insurance shall be shown separately. Loading will be done by vendor and unloading will be done by OPGC.
04. Taxes & Duties: GST & other statutory levies should be separately indicated.
05. Despatch: The consignment shall be despatched to Ib Thermal Power Station to the consignee on door delivery and freight paid basis after necessary inspection and despatch instruction by OPGC Engineer.
06. Validity: The price quoted should remain valid for a period of 90 days w.e.f. date of opening of Bid.
07. Delivery: Delivery of the materials shall be completed within 30 days from the date of issue of LOI/PO.
08. Standard: The material to be supplied shall be strictly as per relevant IS. The supplier must fulfil all the statutory requirements.
09. Testing: Metallurgical Test Report from govt. Approved /OEM laboratory to be submitted along with the supply. OPGCL may incorporate any other testing or inspection if required at your cost.
10. EMD: Vendor must submitted Requisite EMD can be submit directly in our company name – Odisha Power Generation Corporation Limited, Banharpali. Account number of State Bank of India – 10765789090(Code No. 9510). Account number of Central Bank of India, ITPS Banharpali – 2062780721. Account number of Andhra Bank, Adapada – 066211011000005 (Code-0662).
- Otherwise vendors can submit directly in our company name – Odisha Power Generation Corporation Limited, Banhapali. Account number of State Bank of India - 10765789090(Code No. 9510). Account number of Central Bank of India, Belpahar – 2062780721(Code-3899). Account number of Andhra Bank, Adhapada - 066211011000005 (Code-0662). Offer may not be consider without submission of EMD.
11. Security Deposit: EMD will be converted into Security Deposit. Security deposit shall be released after supply is complete successfully.
12. Payment: 100% payment will be released within 30 days of receipt & acceptance of material at site our against submission of bills & other relevant documents.
13. Guarantee: The merchantability & fitness of the material, chemical composition and performance should be guaranteed against any manufacturing defect for a period of 12 months from the date of use or 18 months from the date of supply whichever is earlier.
14. Tax Document: Bidders shall be required to furnish the Photocopy of valid PAN & GST registration certificate.
15. Company price list and recent PO copies of other customer in support of price justification shall be submitted along with offer.
16. Valid authorization certificate must be enclosed along with offer in case of dealer / distributor / stockiest.
17. Bank Mandate form to be submitted to make your payment through RTGS/ NEFT.
18. Penalty: If the materials shall not be delivered within stipulated date, penalty @0.5% of the value of the material not delivered per week of delay or part thereof, subject to maximum 5% of total value, shall be deducted. In case the materials are not supplied as per schedule M/s OPGCL reserves the right to procure from open market and recover the extra expenditure incurred from you. In case where delivery schedule is not adhered to and there are increase in ED and Sales Tax and impose of new duties after scheduled delivery period you shall bear the impact of those levies.
19. Loading: Loading of different factor of commercial terms will be done if the offer is not submitted in line with our tender.



# Odisha Power Generation Corporation Limited

## IB Thermal Power Station

20. Deviations: Deviations from the tender details to be clearly mentioned or else it will be assumed that the parameters in the tender enquiry are accepted.
21. Jurisdiction of Court: All or any differences or disputes arising out of or related to this order shall be decided by Courts in Jharsuguda under Odisha High Court only.

Dy. General Manager, Purchase Materials

### NIT No.- ITPS/ (Purchase)/2018-2019/11(P) dt.05/05/2018

The bid should be sealed properly super scribing "N.I.T No. ITPS/(Purchase)/2018-2019/ 11(P) dt05/05/2018, due on 18/06/2018 for supply of half round sleeve, U clamps & screen tube box.

Your offer should reach this office on or before 18/06/2018 up to 15.00 hrs. Bid shall be opened on 18/06/2018 (same day) at 15.30 hrs in presence of either the bidder or their authorized representative.

The EMD of unsuccessful bidders shall be returned within 30 days of order placement. Bids not submitted in sealed envelope are liable to be rejected. Offer shall not be considered without EMD. E-Mail offer is not acceptable to us.

Offer received late due to postal or courier delay shall not be entertained. The bidders at their own interest should ensure delivery of the bid well in advance. If the bid opening date falls on declared Holiday the bid shall be opened in the next working day at the same time.

Bidders are requested to send their seal bid through register post or speed post in our address. Any bidders chose to send their bid through courier; they are requested to choose our rate contract courier service i.e. **first flight courier** of JHARSUGUDA branch and mention pin code – 768201 or 768202.

M/s OPGCL reserves the right to accept, reject all or any bid & can split among the bidders without assigning any reason thereof.

AGM (SCM)



# Odisha Power Generation Corporation Limited IB Thermal Power Station

## Bank MANDATE FORM for e-payment (To be submitted in Duplicate)

To.  
Odisha Power Generation Corporation Ltd.,  
Ib thermal power station,  
Banharpali,  
Odisha

Dear Sir,

Sub:- Authorization for release of payment due from OPGC Ltd through e-mode facilities of RTGS / NEFT / Internet Banking.

We are the regular contractor/Supplier to your organization and are executing work /supplying materials under different Contracts/ Purchase Orders to OPGC Ltd. We request you to release the payment of the outstanding amount electronically i.e, through RTGS, NEFT, Fund Transfer or any other suitable way. The details of our bank account are as follows: -

(Please fill in the information in CAPITAL LETTERS. Please TICK wherever it is applicable)

1. Name of the Party: .....

2. Address of the Party .....

City ..... Pin Code .....

E-mail ID .....

Permanent Account Number .....

Telephone/Cell No.....

3. Particulars of Bank :

Bank Name		Branch Name	
Branch Place		Branch City	
Pin code		Branch Code	
MICR No			
Account Type	Savings:	Current:	Cash Credit:
Account No. ( as appearing in the Cheque Book) :			
(9 Digits code number appearing on the MICR Bank of the cheque supplied by the Bank. Please attach Xerox copy of a cheque of your bank for ensuring accuracy of the bank name, branch name & code and Account number)			
IFSC Code			

4. Date from which the mandate should be effective :

I hereby declare that the particulars given above are correct and complete. If any transaction is delayed or not effected for reasons of incomplete or incorrect information, I shall not hold Odisha Power Generation Corporation Ltd responsible. I also undertake to advise any change in the particulars of my account to facilitate up dation of records for purpose of credit of amount through internet / RTGS / NEFT.

Place:

Date :

Signature of the Party / Authorized Signatory

.....  
Certified that particulars furnished above are correct as per our records.

Bank's Stamp:

Date:

(Signature of the Authorized Official from the Banks