

ODISHA POWER GENERATION CORPORATION LTD.
(A Government Company of the State of Odisha)
CIN : U40104OR1984SGC001429

2x210 MW, 2x660MW Ib Thermal Power Station, Banharpali, Jharsuguda, Odisha-768 234, India.
Purchase: +91 6645 289 328, Email: manoj.behera@opgc.co.in

Notice Inviting Tender

NIT No: ITPS/Pur/24-25/89

Last date for bid submission	Bid Opening timeline
Date: 10.03.2025	Date: 10.03.2025
Time: 15:00 hrs	Time: 15:30 hrs

EMD: Rs.32,000/-

To,

The Bidder,

Sealed bids in **two parts** (Techno-Commercial Bid and Price Bid) super scribing "Tender Enquiry. No. and due date" as mentioned under reference above are invited for supply and delivery of the following item(s) to Ib Thermal Power Station. The instruction to tenderers is given overleaf.

- Complete and signed sealed bids in hard copy form only shall be received at the SCM Department, ITPS.
- Bids shall be opened at the SCM Department, ITPS in the presence of the bidders or their authorized representatives, if present at the time of opening. An authorized representative must be Proprietor / Partner / Director or Permanent Employee with special authorization for this purpose.
- If the last date of issue/receipt/opening happens to be a HOLIDAY/office closed, the tender will be issued/received/opened at the respective time on the next working day.
- The photocopies of all the supporting documents required for participating in the tender mentioned in the tender paper shall be submitted along with the bid; otherwise, the bid is liable for rejection.
- Bids without EMD will be rejected outright.
- Bids received after the stipulated date & time shall not be entertained.
- OPGC shall not take any liability on account of any postal/courier delay.
- OPGC reserves the right to accept/reject any or all tenders, seek additional clarifications, split up the scope among eligible bidders or cancel the tender altogether without assigning any reasons thereof.
- 1:1 interchangeability certificate to be submitted along with supply (If applicable).
- Guarantee/Warranty certificate to be submitted along with supply (If applicable).
- Material Test Certificate to be submitted (If applicable).
- Vendors are requested to kindly furnish their PAN & GST Numbers. GST certificate to be submitted.
- Bank Mandate form to be submitted to make your payment through RTGS/NEFT.

ODISHA POWER GENERATION CORPORATION LTD.

(A Government Company of the State of Odisha)

CIN : U40104OR1984SGC001429

2x210 MW, 2x660MW Ib Thermal Power Station, Banharpali, Jharsuguda, Odisha-768 234, India.

Purchase: +91 6645 289 328, Email: manoj.behera@opgc.co.in

- OEM Certificate must be submitted. In the case of dealer/distributor/stockiest, a valid authorization certificate must be submitted.
- PO copies & company price list are to be submitted for price justification.
- Import license along with supporting documents to be submitted as applicable
- The quotation in two parts along with EMD (if applicable) is required to be submitted in an envelope as a sealed hard copy Bid. Tender to be submitted at Resource Center, ITPS, Odisha Power Generation Corporation Ltd., Banharpali, Jharsuguda, Odisha (768234). Tender sent by Post/ Courier to be addressed to Asst. Manager, Purchase, Resource Center, ITPS, Odisha Power Generation Corporation Ltd., Banharpali, Jharsuguda, Odisha (768234) superscribe the Tender No and Date of Opening.
- Indented Qty. may be changed at the time of purchase order.
- Delivery: As mentioned in the tender document.
- Payment Terms: As mentioned in the tender document.
- Price offered should be of FOR destination, IB Thermal Power Station. P&F, Freight, Insurance, GST and other landed cost components quoted, if any, are to be indicated in terms of percentage of basic price/fixed price or will be loaded maximum for evaluation of bids.
- Offer may not be considered without valid GST. Please enclose the product catalogue & company price list. The offer will remain valid for 180 days from the date of tender opening. TDS @20% should be deducted from your bill in case of non-submission of PAN details.

Thanking you,

Your faithfully,

(Purchase)

ODISHA POWER GENERATION CORPORATION LTD.

(A Government Company of the State of Odisha)

CIN : U40104OR1984SGC001429

2x210 MW, 2x660MW Ib Thermal Power Station, Banharpali, Jharsuguda, Odisha-768 234, India.

Purchase: +91 6645 289 328, Email: manoj.behera@opgc.co.in

INFORMATION TO BIDDERS

A. PREPARATION OF BID:

1. The bidder(s) shall submit the bid in two parts, namely-

- I) Techno commercial Bid and
- II) Price bid

PART-I: TECHNO-COMMERCIAL BID

The techno-commercial bid shall consist of the following documents:

- A complete set of original Tender documents as issued to the Bidder duly filled in as prescribed in different clauses of the Tender documents with signature & stamp on all pages as a token of unconditional acceptance.
- **Deviation Statement:** In normal cases no deviation is admissible, however, in case of any deviation, a deviation statement mentioning clause no and the deviation details is to be submitted by the bidder.
- **Earnest Money Deposit (EMD):** EMD of **Rs.32,000/- (Rupees Thirty two thousand only)** is required to be submitted for the above tender. The EMD shall be in the shape of Demand Draft/Pay Order/Bank Guarantee (BG as per attached format & shall be valid for 06 months) in favour of "ODISHA POWER GENERATION CORPORATION LTD" drawn on State Bank of India (Code-9510) / Union Bank of India (Code-UBIN0806625) / Central Bank of India (Code-283899) shall be submitted.
- **Unpriced Bid:** Bidders must submit the unpriced bid and must specify whether they have "Quoted" or "Not Quoted" & also indicate the make/brand quoted against each item unpriced bid format enclosed in the tender document.
- GST Certificate copy.
- PAN Certificate copy
- Supporting documents as mentioned in Qualifying Criteria.
- Dully filled proforma for summary quotation (Annexure-I).

Note: If required additional sheet may be used to furnish all the above information but in the format provided in the general conditions of the contract.

ODISHA POWER GENERATION CORPORATION LTD.

(A Government Company of the State of Odisha)

CIN : U40104OR1984SGC001429

2x210 MW, 2x660MW Ib Thermal Power Station, Banharpali, Jharsuguda, Odisha-768 234, India.

Purchase: +91 6645 289 328, Email: manoj.behera@opgc.co.in

The techno-commercial bid with all its enclosures as mentioned should be put in an envelope, sealed & super scribed as a "Techno-Commercial Bid". This envelope must contain the name of the supply, Tender enquiry no., the due date of opening and the name & address of the bidder on the bottom left-hand corner of the cover.

PART-I I: PRICE BID

Original price bid duly filled in, signed & stamped on each page shall be submitted. Any price breakup (if required) must be submitted separately. The rates offered by the bidder shall be written in English (clearly handwritten or typed) both in words and figures and shall be free from any aberrations, deletions, corrections and overwriting. In case of illegible offer submitted by the bidder, the interpretation by OPGC shall be final and binding on the bidder. Insertion, postscript, addition and alteration shall not be accepted after submission of the bid.

Price bids of only those bidders will be opened who meet the required criteria. The Owner shall not entertain any correspondence with any Bidder about the acceptance or rejection of any Price Bid.

Both the "Techno commercial bid" and "Price bid" duly sealed in a separate envelope should be sealed and covered with another bigger envelope and this envelope must contain the name of the work/supply, TE No, due date of opening and name & address of the bidder on the bottom left-hand corner of the cover.

NOTE: TENDERS SUBMITTED WITHOUT THE ABOVE REQUIREMENTS SHALL BE LIABLE FOR REJECTION.

B. OTHER TERM AND CONDITIONS

- 1) OPGC will award the purchase order to the successful bidder whose bid has been found the evaluated lowest i.e. on an L-1 basis. The tender will be finalised on the item-wise L1 basis or package basis considering the bids received. The firm has to accept a part order in case OPGC decides to go for items wise L1 basis Purchase Order.
- 2) OPGC reserves the right to evaluate the quotation on such deviations having financial implications by adding the cost determined by OPGC.
- 3) Wherever it is mentioned in the specification that the contractor shall perform certain work or provide certain facilities, it is understood that the contractor shall do so at his cost.

ODISHA POWER GENERATION CORPORATION LTD.

(A Government Company of the State of Odisha)

CIN : U40104OR1984SGC001429

2x210 MW, 2x660MW Ib Thermal Power Station, Banharpali, Jharsuguda, Odisha-768 234, India.

Purchase: +91 6645 289 328, Email: manoj.behera@opgc.co.in

- 4) Before quoting the rates, the bidder should go through the specifications, scope of work, and special terms and conditions of tender etc. and get himself fully conversant with them.
- 5) The details of items in the price schedule shall be read in conjunction with the corresponding technical specifications. Items of work provided in the price schedule but not covered in the technical specifications shall be executed strictly as per instructions of the engineer in charge.
- 6) OPGC reserves the right to accept the whole or any part of the tender and the bidder shall be bound to perform the same at their quoted rates.

Note:

- Item-wise HSN Code with GST rate applicable to be indicated in the offer
- Further please note to submit your offer considering GST provision and its related input tax credit benefits to be passed on to OPGC
- Bidders have to follow the general instructions while submitting the price bid.
- **EMD Waiver Clause:** Micro, Small & Medium Enterprises (MSMEs) who are registered with DIC/KVIC/KVIB/Coir Board/NSIC/DHH/Udyog Aadhar for the relevant category and manufacturer of the indented items are eligible to get the benefit of exemption from payment of EMD & Tender cost and to get the exemption, the participating bidders have to obtain/register as MSME for the specific service/supply of goods/both.

To get the exemption of EMDs & tender fee, the party has to make an application to the head of supply chain management (SCM) who is conducting the tendering process along with proof of documents regarding eligibility of the exemption at least 2 days before the last day of bid submission. The HOD after due examination will be allowed to participate without submission of EMD& tender fee & the same has to be communicated to the bidder in writing.

- The Earnest Money of all unsuccessful Bidders will be returned within thirty (30) days after the award of the Contract.
- No interest will be payable by the Owner on the said amount covered under Earnest Money / other security deposits.
- On finalization of the Tender, the Earnest Money deposited in the form of DD of the successful Bidder will be treated as part of the initial security at the option of the said supplier or shall be returned to the successful bidder at his option on submission of requisite security deposit.



ODISHA POWER GENERATION CORPORATION LTD.

(A Government Company of the State of Odisha)

CIN : U40104OR1984SGC001429

2x210 MW, 2x660MW Ib Thermal Power Station, Banharpali, Jharsuguda, Odisha-768 234, India.

Purchase: +91 6645 289 328, Email: manoj.behera@opgc.co.in

- A Bidder shall submit the Tender which satisfies each and every condition laid down in this notice and other tender documents, failing which the Tender will be liable to be rejected.
- The ODISHA Power Generation Corporation Ltd. do not bind themselves to accept the lowest or any tender or to give any reasons for their decision. The Owner reserves the right to allow the Public Sector Undertakings price preference facilities as admissible under existing Govt. policy. The prospective Bidders may apprise themselves of the relevant Govt. notification in this regard before submission of their bid. The ODISHA Power Generation Corporation Ltd. reserves the right to accept the whole or any part of the Tender or split the total scope of work among eligible Bidders and the Bidder (s) shall be bound to perform the same at his/their quoted rates.
- OPGC reserves the right to accept/reject any or all tenders, split up the scope among eligible bidders or cancel the tender altogether without assigning any reason thereof.
- Bidder has to submit the price bid as per the price bid format.
- Vendors are requested to submit their seal offers at our office by sending through DTDC **COURIER / SPEED POST/REGISTER POST/By Person.**
- OPGC reserves the right to accept the whole or any part of the tender and the bidder shall be bound to perform the same at their quoted rates.

Note: Tenders submitted without the above requirements shall be liable for rejection.

ODISHA POWER GENERATION CORPORATION LTD.

(A Government Company of the State of Odisha)

CIN : U40104OR1984SGC001429

2x210 MW, 2x660MW Ib Thermal Power Station, Banharpali, Jharsuguda, Odisha-768 234, India.

Purchase: +91 6645 289 328, Email: manoj.behera@opgc.co.in

SPECIAL TERMS AND CONDITONS

1.0 Delivery Period & LD Charges:

The material shall be delivered within 60 days from the LOI / PO date. The vendor is liable to pay a penalty at the rate of 0.5 % of the cost of undelivered materials per week or part thereof subject to a maximum of 05 % of the cost of undelivered materials. If the delay is beyond 10 weeks or less depending upon the requirement, the buyer reserves the right to cancel the PO and collect the materials from any other source at the risk of the original supplier without making any reference to him. The additional financial involvement occurs if any from procuring other sources shall be recovered from you.

2.0 Inspection/PDI:

Materials shall be subjected to inspection at vendor site by any of the OPGCL approved Third Party Inspection (TPI) agency or company representative or at OPGC site with mutual agreement and accepted by EIC.

3.0 Quality:

Quality of material as per the specification and accepted by the EIC.

4.0 Payment Terms:

SUPPLY: 90% of the basic price with full taxes and duties will be paid within 30 days of receipt and verification of materials at our site. Balance 10% will be released within 90 days after submission of Performance Bank Guarantee of the equivalent amount till the guarantee period i.e. 18 months from the date of supply or 12 months from the date of use, whichever is earlier with an additional validity of 03 months as claim period.

5.0 Security deposit:

The bidder shall submit a security deposit i.e. 05% of the PO basic value in the shape of a DD/irrevocable bank guarantee valid for six months/up to delivery period whichever is later plus a 2-month claim period from a nationalized/scheduled bank executed on non-judicial stamp paper of appropriate value towards execution of the contract. The security deposit shall be released after the supply is complete. If the supplier fails or regrets to observe or perform any of his obligations under the contract, it shall be lawful for the purchaser to forfeit either in whole or part, in his absolute discretion, the security deposit furnished by the supplier. The forfeiture of the security deposit shall be without prejudice to the right of the purchaser to recover any further amount of any liquidated and/or other damages, undue payment or overpayment made to the supplier under this contract or any other contract claim of the supplier shall be entertained against the purchaser either in respect of interest or depreciation in the value of security deposit. Security deposit is to be submitted within 15 days of placement of LOI/PO

6.0 Performance bank guarantee:

performance bank guarantee valid for 21 months (18 months + 03 months grace period) from the receipt of materials or 15 months (12 months + 03 months grace period) from the date of use shall be submitted by the firm for performance of the equipment or spares supplied by the successful bidder.

7.0 Acceptance to part order:

All firms must accept part order supply for the above tender. Non-acceptance may lead to rejection of the bid submitted.

ODISHA POWER GENERATION CORPORATION LTD.

(A Government Company of the State of Odisha)

CIN : U40104OR1984SGC001429

2x210 MW, 2x660MW Ib Thermal Power Station, Banharpali, Jharsuguda, Odisha-768 234, India.

Purchase: +91 6645 289 328, Email: manoj.behera@opgc.co.in

8.0 (a) Preparation of comparative statement:

The vendor should note the following, loading factors to be used by OPGC during the evaluation process in case the same has not been considered during offer submission.

P&F charges	2%
Freight less than 300 km	3%
300 km. To 500 km	4%
500 km. To 1000 km	5%
Above 1000 km	6%
Insurance	0.086%

(Note: percentage loading will be limited to full truck/trailer load rate for each truck load).

(b) Payment terms loading

1.5% per month (wherever parties have quoted 100% through bank/advance against our standard and payment terms of bid documents)

In case of payment through bank loading for 30 days and in case of advance payment along with PO the loading for the period of delivery period plus 30 days, may be taken. In case of 90% through bank & balance 10% within 30 days after receipt and acceptance of materials.

The loading factor will be $1.5 \times 0.9 = 1.35\%$. Accordingly, for other payment terms, loading factors will be calculated.

9.0 Loading procedures

Basic price	
Packing & Forwarding charges	(on basic price only)
Freight on	(basic + p&f)
Insurance on	(basic + p&f + freight)
GST	(basic + p&f + freight + insurance)
Payment terms loading on	(basic + p&f + freight + gst)

10.0 Weight/length variation

In case the payment is done on weighing the consignment at the site, an allowable tolerance of +/- 0.25% shall be applicable. This tolerance shall be allowed as weighbridge tolerance due to being weighed in two different weighbridge (if available). For any variation beyond this allowable tolerance, necessary adjustments shall be made during releasing payment by way of submission of a credit note by the vendor. If the weight variation is +/- 0.25% from the invoiced weight/challan weight the invoiced weight will be accepted for account as well as payment. If there are three continuous negative tolerance is found no more tolerance shall be allowed. The vendor shall have to submit the credit as per weight by OPGC.

11.0 OPGCL reserves the right not to accept the lowest rate quoted by the bidder and reject any or all the offer without assigning any reason whatsoever. M/s OPGC Ltd. also reserves the right to accept /reject /split any tender without assigning any reason thereof.

12.0 Special terms and conditions supersede General Terms and conditions.

ODISHA POWER GENERATION CORPORATION LTD.

(A Government Company of the State of Odisha)

CIN : U40104OR1984SGC001429

2x210 MW, 2x660MW Ib Thermal Power Station, Banharpali, Jharsuguda, Odisha-768 234, India.

Purchase: +91 6645 289 328, Email: manoj.behera@opgc.co.in

GENERAL INSTRUCTIONS

1. Each tender should be sent in a properly sealed envelope addressed to the Purchase (Head), Ib Thermal Power Station, Banharpali, Dist. Jharsuguda, PIN: 768234. The envelope should bear the tenderer's distinct rubber stamp. Tender No. _____ due on dt. _____ should invariably be given on the cover.
2. In the case of items of a specific make, only manufacturers and their accredited agents/stockiest/authorized dealers are entitled to quote. For this, they should submit an attested copy of the printed price list along with the tender.
3. The tenders submitted must be free from overwriting or eraser. Corrections & additions if any must be attested. Incomplete tender should not be submitted. Tenders received after the due date of opening will not be entertained.
4. The required EMD in the shape of DD payable at State Bank of India (Code-9510)/Central Bank of India, Banharpali (Code-0283899)/ Union Bank of India, Adapada (Code-806625), Ib Thermal Power Station, Banharpali, Jharsuguda in favour of Odisha Power Generation Corporation Limited. Otherwise, you can submit directly in our company name - Odisha Power Generation Corporation Limited, Banharpali. Account number of State Bank of India - 10765789090 (IFSC- SBIN0009510). Account number of Central Bank of India, ITPS, Banharpali – 2062780721 (IFSC-CBIN0283899). Account number of Union Bank of India, Adapada - 066211011000005 (IFSC-UBIN0806625). In case EMD is submitted in the form of DD, the DD shall be valid for three (03) months from the date of opening of the price bid.
5. The offer given must remain valid for 180 days from the date of opening of the price bid.
6. Manuals/Pamphlets/Leaflets and drawings illustrating technical details/year of manufacture, maker name, and country of origin must be enclosed with the tender, sample if required should be submitted along with the tender.
7. The price quoted should be firm and delivery F.O.R destination inclusive of packing, forwarding, transportation and insurance charges except duties & taxes. Rebate discount if any given may also be mentioned.
8. The percentage of GST declared to be charged should be distinctly shown along with the price quoted. GST Registration number must be indicated invariably.
9. The tenderers should be able to complete delivery within 20 to 30 days from the date of receipt of the purchase order/delivery clause as mentioned herein or else LD @0.5% per week or maximum @ 5 % will be applicable from the due date.
10. The tender should be agreeable to our payment terms, i.e. 100% within 30 days of receipt and acceptance of materials at the Site. Payment terms if mentioned under special terms & conditions shall prevail over the above clause.
11. The quality of materials to be supplied should be brand new, free from all flaws, good finish and should be as per technical specification and relevant to IS specification.
12. The merchantability & fitness of the materials should be guaranteed against any manufacturing defect or bad workmanship for 12 months from the date of use or 18 months from the date of supply whichever is earlier. An extra 03 months grace period shall be provided by them for lodging or claiming for the same.

ODISHA POWER GENERATION CORPORATION LTD.

(A Government Company of the State of Odisha)

CIN : U40104OR1984SGC001429

2x210 MW, 2x660MW Ib Thermal Power Station, Banharpali, Jharsuguda, Odisha-768 234, India.

Purchase: +91 6645 289 328, Email: manoj.behera@opgc.co.in

13. The tender must accompany a photocopy of the latest & valid Income Tax Clearance Certificate & Good & Service Tax Clearance Certificate without which the tender will be rejected.
14. Destination means Central stores, Ib Thermal Power Station, Banharpali.
15. Whenever tenderers have entered into a Rate Contract with DGS&D or EPM, they will indicate the same in their tenders and submit a copy of the rate contract as proof of claim.
16. All Bank charges to the vendor's account.
17. The weight of each item after packing shall have to be mentioned in your offer, otherwise maximum freight charges shall be loaded.
18. The quantity indicated in this enquiry is provisional and subject to change.
19. The undersigned reserves the right to accept/reject any or all the tender without assigning any reason thereof.
20. Supplier having experience of supplying similar items and credentials to other Thermal Power Stations
21. **Jurisdiction:** All contracts effected between OPGCL and the vendor shall be subject to Jharsuguda Court Jurisdiction and shall be governed by Law. It is agreed that no other court shall have jurisdiction to entertain any suit or proceedings, even though, part of the cause of action might arise within their jurisdiction. In case any part of the cause of action might arise within the jurisdiction of any other Courts in Odisha, and rest within the jurisdiction of Courts outside the State of Odisha, then it is agreed to between the parties that such suits on proceedings shall be instituted in a Court within the State of Odisha and no other Court outside the State of Odisha have jurisdiction.
22. **Arbitration:** In case of any dispute arising out of the supply or interpretation of the meaning of the terms in these conditions of purchase or any alleged breach thereof, the same shall be referred to an independent Arbitrator/s selected by the aggrieved party and consented by the other party. The arbitration shall be conducted in accordance with the provision of the Indian Arbitration Act of 1996 or modifications thereof and the award of the Arbitrator shall be final and binding on both parties. The arbitrations shall be conducted at Jharsuguda or at such place as decided by the Arbitrator. The cost, incidentally shall be borne by the vendor.
23. **Litigation:** All expenses and costs in connection with litigation, if any, will be to the vendor account.
24. **Force majeure:** Any delay or failure to perform the contract by either party caused by acts of god or acts of government or any direction or restriction imposed by the government of India which may affect the contract or the public enemy or contingencies like strikes, riots etc. Shall not be considered as default for the performance of the contract or give rise to any claim for damage. Within 7 days of occurrence and cessation of the event(s), the other party shall be notified. Only those events of force majeure that impede the execution of the contract at the time of its occurrence shall be taken into cognizance.
25. **Patents, royalties, seller's liability and compliance with regulations:** The vendor shall protect and fully indemnify the purchaser from any claims for infringement of patents, copyrights, trade mark or the like. The seller shall also protect and fully indemnify the purchaser from any claims from the seller's workman/employees, their heirs, dependents, representatives etc. Or from any other person/persons or bodies/companies etc. For any act of commission or omission while executing the order. Seller shall be responsible for compliance with all requirements under the laws and shall protect and indemnify completely the purchaser from any claims/penalties arising out of any infringement.

ODISHA POWER GENERATION CORPORATION LTD.

(A Government Company of the State of Odisha)

CIN : U40104OR1984SGC001429

2x210 MW, 2x660MW Ib Thermal Power Station, Banharpali, Jharsuguda, Odisha-768 234, India.

Purchase: +91 6645 289 328, Email: manoj.behera@opgc.co.in

- 26. Vendor Banning & Blacklisting:** If the vendor fails to comply with the terms and conditions of the Purchase Order (PO), including but not limited to delayed delivery, supply of substandard or non-conforming materials, breach of contractual obligations, or withdrawal from the contract after acceptance of the PO, M/s OPGCL reserves the right to ban, blacklist, or suspend the vendor from participating in future tenders and procurements as per OPGC vendor banning policy. Additionally, such action may be communicated to other Public Sector Undertakings (PSUs), government bodies, and relevant industry authorities. The vendor shall have no claim or liability for such decisions taken by M/s OPGCL in the interest of ensuring reliable and ethical procurement practices.
- 27. Fall Clause:** The bidder shall confirm that the prices quoted in their bid are not higher than the rates offered to any other government organization, public sector undertaking (PSU), or any other customer for the same or similar items under similar terms and conditions. If at any time during the contract period, the bidder supplies or agrees to supply the same or similar items at a lower price to any other entity under similar terms and conditions, the bidder shall immediately offer the same reduced price to M/s OPGCL. Failure to comply with this clause may result in downward revision of contract prices to match the lower price and/or recovery of excess payment made by M/s OPGCL due to the price difference and/or blacklisting or banning from future tenders and procurement processes. The bidder shall furnish an undertaking confirming adherence to this “Fall Clause” at the time of bid submission.

ODISHA POWER GENERATION CORPORATION LTD.
(A Government Company of the State of Odisha)
CIN : U40104OR1984SGC001429

2x210 MW, 2x660MW Ib Thermal Power Station, Banharpali, Jharsuguda, Odisha-768 234, India.
Purchase: +91 6645 289 328, Email: manoj.behera@opgc.co.in

BOQ

Material Code	Material Description	Qty. (A)	UoM	Unit Price in Rs. (B)	Amount in Rs. (A X B)
155470242001	IDLER FRAME SELF ALIGNING CARRYING	60	No		
155470222002	IDLER FRAME FLAT RETURN TRAINING	40	NO		
Refer to the drawing attached.					
Total Amount in Rs.					

Applicable GST %:

HSN Code:

Other commercial conditions if any shall be clearly indicated.

Note: Bidder has to use the above Price Bid Format failing which Bid may be rejected.



OPGC
Power for Progress

ODISHA POWER GENERATION CORPORATION LTD.

(A Government Company of the State of Odisha)

CIN : U40104OR1984SGC001429

2x210 MW, 2x660MW Ib Thermal Power Station, Banharpali, Jharsuguda, Odisha-768 234, India.

Purchase: +91 6645 289 328, Email: manoj.behera@opgc.co.in

ANNEXURE-I

PROFORMA FOR SUMMARY QUOTATION for Technical & un-priced Commercial bid (Part-1)

NIT No.: ITPS/Pur/24-25/89

Due Date: 10.03.2025

Sl. No.	Techno Commercial Points	OPGCL Needs	To be filled by the bidder
1	Technical Specification as per Tender Enquiry	Accepted/ Not accepted. If not accepted detail Deviation and proposal.	
2	Credentials as per Qualifying requirement	Submitted / Not submitted as per bid requirement.	
3	The Bidder must be a reputed manufacturer/ authorised dealer/ stockiest of the preferred makes, and financial capability and have supplied such items to other Industrial concerns of repute.	Yes/ No.	
4	All Tests are to be carried out as per the bid document	Yes/ No.	
5	Bidder has to submit requisite EMD either in the shape of DD payable on State Bank of India (Code No. 9510) Banharpali/Central Bank of India, Ib Thermal Power Station (Code-0283899)/ Andhra Bank, Adapada(Code-0662), Ib Thermal Power Station, Banharpali, Jharsuguda in favour of Odisha Power Generation Corporation Limited.	Submitted/Not submitted details to be mentioned	
6	Price Basis	FOR Destination Ib Thermal Power Station. Parties offering FOR Ex. Works please give the place of works.	
7	Packing & Forwarding charges % or Rs..... in Lump sum Inclusive/ Exclusive.	
8	GST in % % Inclusive/ Extra/Not applicable.	
9	Transportation Cost	Rs.---- per No./Lump sum. As extra/Inclusive	
10	Transit Insurance % extra/inclusive	
11	Delivery Schedule	60 days Accepted/ Not Accepted	.
12	Validity of offer	180 days from the due	

Regd. Office: Zone-A, 7th Floor, Fortune Towers, Chandrasekharapur, Bhubaneswar-751023, Odisha.

Ph: 0674-2303765-66, Fax: 0674-2303755/56, Website: www.opgc.co.in



OPGC
Power for Progress

ODISHA POWER GENERATION CORPORATION LTD.

(A Government Company of the State of Odisha)

CIN : U40104OR1984SGC001429

2x210 MW, 2x660MW Ib Thermal Power Station, Banharpali, Jharsuguda, Odisha-768 234, India.

Purchase: +91 6645 289 328, Email: manoj.behera@opgc.co.in

		date of opening date of the Part-1 bid.(Techno Commercial). Accepted/ Not accepted.	
13	Liquidated damage clause is applicable if delivery is delayed beyond the quoted delivery date @0.5% per week/part of the week subject to 5 % of PO value.	Accepted/ not accepted. Non-acceptance shall lead to loading of your Offer by 5%.	
14	The bidder has to accept our payment terms as per NIT.	Accepted/ Not accepted. (in case non-acceptance loading shall be done)	
15	Acceptance of part order quantity	Yes/ No	
16	Packing material as per OPGCL term to use non asbestos and environmentally friendly material.	Yes/ No	
17	Payment is to be made through the RTGS mode	Accepted/ Not accepted.	
18	All Bank charges to the vendor account	Accepted/ Not accepted.	
19	Tender Notice NIT general Terms & Conditions	Accepted/ Not accepted.	
20	Tender Notice NIT Special Terms & Conditions	Accepted/ Not accepted.	
21	List of Deviation statements from tender norms.	Submitted/ Not submitted	
22	All relevant documents submitted against "Qualification Criteria" in ANNEXTURE-II	Submitted/ Not submitted	

Authorised Signatory:

Name of the firm:

Designation:

Company Seal:

ODISHA POWER GENERATION CORPORATION LTD.
(A Government Company of the State of Odisha)
CIN : U40104OR1984SGC001429

2x210 MW, 2x660MW Ib Thermal Power Station, Banharpali, Jharsuguda, Odisha-768 234, India.
Purchase: +91 6645 289 328, Email: manoj.behera@opgc.co.in

ANNEXURE-II

QUALIFICATION CRITERIA

- a. The Bidder must be a Manufacturer or their authorised dealer/stockiest/distributor of the material, **Idler/Idler Frame**. Certificate of incorporation / ISO certification / Factory license/ Authorisation certificate/ Dealership agreement from the manufacturer (Whichever is applicable) shall be submitted as documentary proof.
- b. The bidder must have supplied a *similar product directly to any industry, preferably to Govt. Organisations/PSU/Private Organizations of repute. Bidder must submit relevant order copies of the last Five (5) Years meeting any of the following criteria.
 - i. One purchase order of order value not less than **Rs.13.00 Lakh**. (OR)
 - ii. Two purchase orders and each order value not less than **Rs.09.5 Lakh**. (OR)
 - iii. Three purchase orders and each order value not less than **Rs.06.00 Lakh**.
- c. Average annual financial turnover during the last three years (i.e., 2021-22, 2022-23 and 2023- 24) should be **Rs.19.00 Lakh** or more. Audited Balance Sheet and profit & Loss A/C must be submitted along with the Techno-commercial Bid. If the account is not audited, a certificate from a chartered accountant should be produced towards turnover.
- d. The bidder must not have been blacklisted or debarred in the last five years to participate in tendering of similar supply earlier by any Govt/Public Sector Utility / IPP/CPP. Self-declaration certificate shall be submitted along with the technical bid.
- e. Must submit a copy of PAN & GST registration along with the technical bids. In case the bidder is registered under MSME/NSIC a copy of the certificate is to be submitted in the technical bid.
- f. The above qualifying criteria do not apply to Govt. Organisations/PSUs.

* Similar product means “Self-aligning carrying and return idler frames”.



OPGC
Power for Progress

ODISHA POWER GENERATION CORPORATION LTD.

(A Government Company of the State of Odisha)

CIN : U40104OR1984SGC001429

2x210 MW, 2x660MW Ib Thermal Power Station, Banharpali, Jharsuguda, Odisha-768 234, India.

Purchase: +91 6645 289 328, Email: manoj.behera@opgc.co.in

Bank MANDATE FORM for e-payment

(To be submitted in Duplicate)

To.
Odisha Power Generation Corporation Ltd.,
IB Thermal Power Station,
Banharpali,
Odisha.

Dear Sir,

Sub: - Authorization for release of payment due from OPGC Ltd through e-mode facilities of RTGS / NEFT / Internet Banking.

We are the regular contractor/Supplier to your organization and are executing work /supplying materials under different Contracts/ Purchase Orders to OPGC Ltd. We request you to release the payment of the outstanding amount electronically i.e., through RTGS, NEFT, Fund Transfer or any other suitable way. The details of our bank account are as follows: -

(Please fill in the information in CAPITAL LETTERS. Please TICK wherever it is applicable)

1. Name of the Party:
2. Address of the Party
- City Pin Code
3. E-mail ID
4. Permanent Account Number
5. Telephone/Cell No.....
6. Particulars of Bank :

Bank Name		Branch Name	
Branch Place		Branch City	
Pin code		Branch Code	
MICR No			
Account Type	Savings:	Current:	Cash Credit:
Account No. (as appearing in the Cheque Book) :			
(9-digit code number appearing on the MICR Bank of the cheque supplied by the Bank. Please attach Xerox copy of a cheque of your bank to ensure the accuracy of the bank name, branch name & code and Account number)			
IFSC Code			

7. Date from which the mandate should be effective :

I hereby declare that the particulars given above are correct and complete. If any transaction is delayed or not effected for reasons of incomplete or incorrect information, I shall not hold Odisha Power Generation Corporation Ltd responsible. I also undertake to advise any change in the particulars of my account to facilitate the updation of records for the purpose of credit of amount through the internet / RTGS / NEFT.

Place:

Date:

Signature of the Party / Authorized Signatory

.....
Certified that the particulars furnished above are correct as per our records.

Bank's Stamp: Date:

(Signature of the Authorized Official from the Banks)



OPGC
Power for Progress

ODISHA POWER GENERATION CORPORATION LTD.

(A Government Company of the State of Odisha)

CIN : U40104OR1984SGC001429

2x210 MW, 2x660MW Ib Thermal Power Station, Banharpali, Jharsuguda, Odisha-768 234, India.

Purchase: +91 6645 289 328, Email: manoj.behera@opgc.co.in

PROFORMA FOR BANK GUARANTEE IN LIEU OF DD FOR EARNEST MONEY

(On Non-Judicial stamp paper of appropriate value)

Ref:
Date:
Bank Guarantee
No.

To
Odisha Power Generation Corporation Ltd.,
Ib Thermal Power Station, At/Po- Banharpali,
Dist-Jharsuguda-768234.

Dear Sir,

In consideration of Odisha Power Generation Corporation having its Registered office at 7th.Floor, Zone – A, Fortune Towers, Chandrasekharpur, Bhubaneswar-751 023 (hereinafter called the "Owner" which expression shall unless repugnant to the subject or context include its successors and assigns) having issued Tender Specification Against NIT

No _____ dt. _____ to M/s _____ having its Registered / Head office at _____ (hereinafter called the Bidder) who wishes to participate in the said tender for and you, as a special favour, have agreed to accept an irrevocable and unconditional Bank Bid Guarantee for an amount of Rs. _____ valid up to _____. On behalf of the Bidder, as a condition for participation in the said tender.

We, the _____ Bank incorporated under _____ law and having one of our branches at _____ and having our registered office/Head office at _____ do here by unconditionally and irrevocably guarantee and undertake to pay to the "Owner" immediately on demand without any demur reservation, protest, contest and recourse to the extent of the said sum of Rs. _____ (Rupees _____ only). Any such claim/demand made by the said "Owner" on us shall be conclusive and binding on us irrespective of any dispute or differences raised by the Bidder. This guarantee shall be irrevocable and shall remain valid up to _____. If any further extension of this guarantee is required, the same shall be extended to such required period on receiving instructions from M/s _____ on whose behalf this guarantee is issued.

We, the said Bank lastly undertake not to revoke this guarantee during its currency except with the previous consent of the owner in writing and agree that any change in the constitution of the said tenderer or the said Bank shall not discharge our liability. In witness where of the Bank, through its authorised officer, has set its hand and stamp on this _____ day of _____ 20_____

Witness:
(Signature) _____

Name _____

(Signature) _____

Name _____

(Designation with Bank stamp)
Official Address _____

Attorney as per Power of Attorney

No. _____

Date _____



ODISHA POWER GENERATION CORPORATION LTD.

(A Government Company of the State of Odisha)

CIN : U40104OR1984SGC001429

2x210 MW, 2x660MW Ib Thermal Power Station, Banharpali, Jharsuguda, Odisha-768 234, India.

Purchase: +91 6645 289 328, Email: manoj.behera@opgc.co.in

PROFORMA OF BANK GUARANTEE FOR MATERIAL PERFORMANCE

(On Non-Judicial Stamp paper of Appropriate Value)

1.0 In consideration of OPGC Ltd. Having its registered office at Zone-A, 7th Floor, Fortune Tower, Chandrasekaharpur, Bhubaneswar-751023, Odisha herein-in after called the “Owner” which expression shall unless repugnant to the subject or context include its successor & assignees) having awarded to M/swith its Registered/Head office at..... here-in after referred to as the “Contractor” which expression shall unless repugnant to the subject or context include its successor, executors & assignees) a contract by issue of Owner’s Letter of Intent No. dt. and the same having been unequivocally accepted by the contractor resulting in a contract bearing No.dated valued at Rs.....for and the contractor having agreed to provide a contract performance (Scope of work) Guarantee for the faithful performance of the entire contract equivalent Rs. 10% (ten percent) of the said value of the contract to the owner for satisfactory performance of the equipment/materials supplied (as detailed in the said agreement) during the Guarantee period (as detailed in the said agreement) and for the due fulfillment by the contractor(s) of the terms and conditions contained in the said agreement.

2.0 We(here-in after referred to as “ the bank”
(Name & address of Bank)
having its Head Office at do hereby guarantee and undertake to pay the owner, on demand any and all amount payable by the contractor not exceeding Rs.(Rupees.....) only as aforesaid at any time up to (Days/month/year)

3.0 We do hereby
(Name of Bank)
Undertake to pay the amounts due to and payable under this guarantee without any demur, reservation, contest, recourse or protest and/or without any reference to the contractor. Any such demand made by the

ODISHA POWER GENERATION CORPORATION LTD.

(A Government Company of the State of Odisha)

CIN : U40104OR1984SGC001429

2x210 MW, 2x660MW Ib Thermal Power Station, Banharpali, Jharsuguda, Odisha-768 234, India.

Purchase: +91 6645 289 328, Email: manoj.behera@opgc.co.in

owner on the Bank shall be conclusive and binding notwithstanding any difference between the owner and contractor or any dispute pending before any court, tribunal or any other authority. The bank undertakes not to revoke this guarantee during the currency without previous consent of the Owner and further agrees that the guarantee herein contained shall continue to be enforceable till the owner discharges this guarantee.

The payment so made by us under this bond shall be a valid discharge of our liability for payment there under and the contractor(s)/suppliers shall have no claim against us for making such payment.

4.0 We further agree that the

(Name of Bank)

guarantee herein contained shall remain in full force and effect during the period that would be taken for the performance of the said Agreement and that it shall continue to be enforceable till all dues of OPGC have been fully paid and its claims satisfied or discharged until OPGC certifies that the terms & conditions of the said Agreement have been fully and properly carried out by the said contractor(s) and accordingly discharges this guarantee.

5.0 We further agree with the

(Name of Bank)

OPGC that OPGC have the fullest liberty without our consent and without affecting in any manner our obligations hereunder to vary any of the terms and conditions of the said agreement or to extend time of performance by the said contractor(s) from time to time or to postpone for any time or from time to time any of the powers exercisable by the OPGC against the said contractor(s) and to for bear or enforce any of the terms and conditions relating to the said agreement and we shall not be relieved from our liability by reason of any such variation, postponement or extension being granted to the said contractor(s) or for any forbearance, act or omission on the part of the OPGC or any indulgence by the OPGC to the said contractor(s) or by any such matter or thing whatsoever which under the law relating to sureties would but for this provision have effect of so relieving us.

6.0 This guarantee will not be discharged due to the change in the name, style and constitution of the Bank or the contractor(s)/suppliers(s).



ODISHA POWER GENERATION CORPORATION LTD.
 (A Government Company of the State of Odisha)
 CIN : U40104OR1984SGC001429

2x210 MW, 2x660MW Ib Thermal Power Station, Banharpali, Jharsuguda, Odisha-768 234, India.

Purchase: +91 6645 289 328, Email: manoj.behera@opgc.co.in

7.0 Notwithstanding anything contained herein a)Our liability under this bank guarantee shall not exceed Rs.....[Rupees]
 b) This bank guarantee shall be valid uptoc) We are liable to pay the guaranteed amount or any part thereof under this B.G only and only if the beneficiary/Govt. serves upon the bank a written claim or demand on or before

8.0 Welastly undertake not to revoke this

(Name of Bank)

Guarantee during its currency except with the previous consent of the OPGC in writing.

Dated theday of200...

9.0 Notwithstanding anything contained hereinabove our liability under this guarantee is restricted to Rs.....
 ...(Rupees.....on ly) and this guarantee is valid upto We shall be released and discharged from all liabilities hereunder unless a written claim for payment under this guarantee is lodged on us within three months from the date of expiry of the guarantee i.e on or before Irrespective of whether or not the original guarantee is returned to us.

The confirmation of this Bank Guarantee is available within our controlling office. The beneficiary in his own interest should obtain such confirmation from the controlling office at the following address

WITNESS with address

For and on behalf of (the Bank)

Signature

1.

Name

2.

Designation

Authorisation No.....

Seal of the Bank

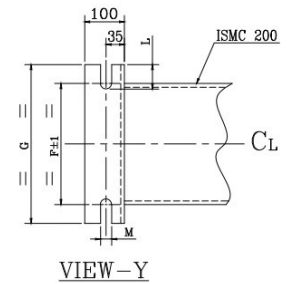
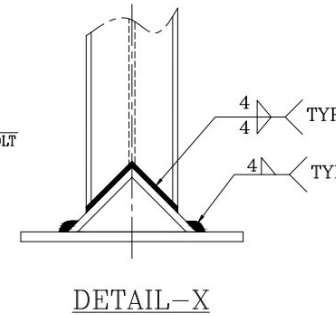
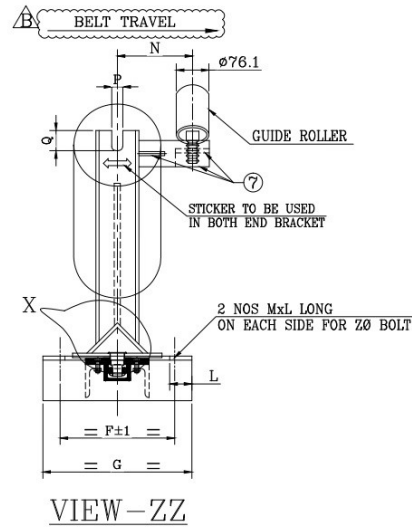
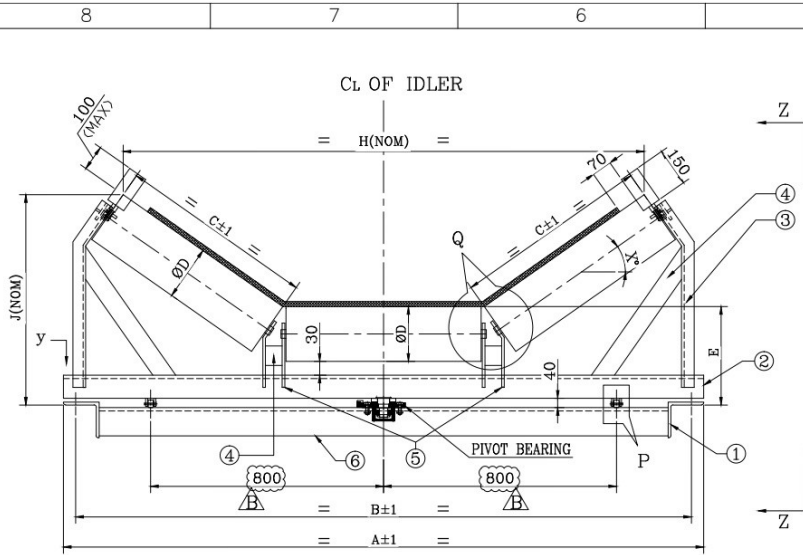

SI NO	B/W	A	B	C	DØ	E ^{±3}	F	G	H (CONSIDERING MAX 'K' VALUE)	J	K	P	Q	L	M	N	X°	SHAFT DIA.	SHAFT DIA AT BEARING	BRG.NO.	BRG.MAKE	WT.OF ROTATING PARTS (KG)	ASSY.WT OF IDLER ASS(KG)	ZØ BOLT	TOTAL QTY
1	1800	2170	2100	670	152.4	275	200	250	1788	660	10	23	40	36	22	150	35	30.15	30	6206-Z	SKF/FAG/NBC	42	125	M20	755 SETS

ALL STRUCTURAL MATERIAL IS OF IS:2062,GR-A

1800 BW	ISA-100X100X10	ISA-100X100X10	ISM 75X40	ISF 50X8	ISF 75X8	ISM 200x75	8 THK. PL.
BASE FDDT(1)	BASE FRAME(2)	END BKT(3)	STIFFNER(4)	MIDDLE BKT(5)	BASE CHANNEL(6)	STIFFNER(7)	

BILL OF MATERIALS

- NOTE:-**
- ALL DIMENSIONS ARE IN MM U.O.S.
 - TUBE THICKNESS WILL BE 4.5 MM WITHOUT NEGATIVE TOLERANCE.
 - ALL IDLER TUBE MATERIAL ERW AS PER IS:9295,(YST-210)-1983.
 - BEARING LIFE IS 30000 WORKING HOURS,-B-10->
 - BEARING SIZE 6206-Z C3 CLEARANCE AND (MAKE-SKF/FAG/NBC).
 - FRICITION FACTOR MAX 0.015 AS PER IS 11592-2000.
 - IDLER ARE DUST PROOF, WATER PROOF & WEATHER PROOF.
 - ALL IDLER ARE MANUFACTURED AS PER IS:8598-1987.
 - SHAFT MATERIAL EN-8/C-40/C-45 BRIGHT BAR AS PER BS:970-1983/IS:1570-1979.
 - TOTAL INDICATOR READING <TIR>ON IDLER OD,WHEN ROTATED TO CHECK RUNOUT AS PER IS:8598-1987.
 - PAINTING WILL BE AS PER CONTRACT SPECIFICATION GID-208-ME-ECS-SA-4515-REV-2, TESTING AND INSPECTION WILL BE DONE AS PER APPROVED QAP.
 - SEALING -GREASE PACKED AND SEALED FOR LIFE LITHIUM BASE GREASED TO BE USED.
 - IDLERS ARE DROP IN TYPE & ROLLS CAN BE REMOVED WITHOUT DISMANTLING THE BRACKET FROM THE CONV. STRUCTURE.
 - ALL ROLLS ARE INTERCHANGEABLE FOR THE SAME BELT WIDTH.
 - IDLERS ARE PROVIDED WITH MULTI LABYRINTH SEALING.
 - ALL FILLET WELD ARE 4 MM (MINIMUM).
 - FOR CROSS SECTION DRAWING OF ROLL ASSY. PLEASE REFER DRG. NO- AAC/BGRESL/CR/014.
 - ALL SHARP CORNERS TO BE GROUND SMOOTH.
 - ALL THE TESTING TO BE DONE AS PER IS:8598-1987.
 - FOR PIVOT BEARING HOUSING & GUIDE ROLLER REFER DRG. NO- AAC/BGRESL/PBHGR/017.

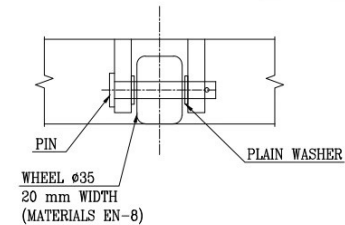
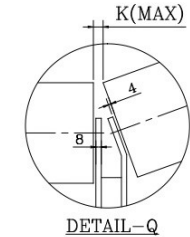
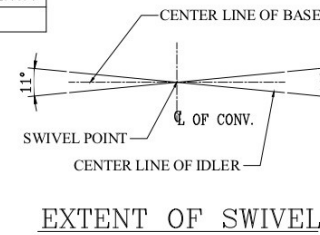

Painting Specification:-

SL.NO.	TYPE	TYPE OF PREPARATION	REFERENCE STANDARD
1	Grade of Surface Preparation	Power Tool Cleaning (Wire Wheel / Wire brush)	SSPC-SP3
	DESCRIPTION	TYPE OF PAINT	No of Coats
2	Primer Coat	Light Grey Zinc Chromate as per IS: 2074 / IS 12744	2
3	Final Coat	Synthetic enamel paint as per IS: 2932	2
Frame Total DFT (microns)			140
4	Primer Coat	Light Grey Zinc Chromate as per IS: 2074 / IS 12744	1
5	Final Coat	Synthetic enamel paint as per IS: 2932	1
Roller Total DFT (microns)			50-70
6	Final Color Shade	DARK ADMIRALITY GREY- Shade No- 632	

OPGC CHP-2

CLIENT:-

NAME	SIGN	DATE
DSGN DHANJEE		23.05.16
DRWN DHANJEE		23.05.16
CHKD MANAS		23.05.16
APPD MANOJ		23.05.16

TITLE:
G.A OF 3-EQUAL ROLL S.A. CARRYING IDLER

PROJECTION

B	10.06.16	REVISED AS MARKED	DHANJEE	DHANJEE	MANAS	MANOJ
A	06.06.16	REVISED AS MARKED	DHANJEE	DHANJEE	MANAS	MANOJ
O	23.05.16	FIRST SUBMISSION	DHANJEE	DHANJEE	MANAS	MANOJ
REV. NO.	DATE	DETAIL OF REVISION	DSGN.	DRWN.	CHD.	APP.

SCALE - NTS	SHEET - 2 of 3	PAGE - A3
CAD SOFTWARE	AutoCAD	

BASIC DATA:-
 CAPACITY:-2600 T.P.H
 DUTY:-CONTINUOUS
 MATERIAL:-COAL
 LUMP SIZE:-(-)100MM.(-)20MM
 BELT SPEED:- 3.14 M/SEC (MAX)

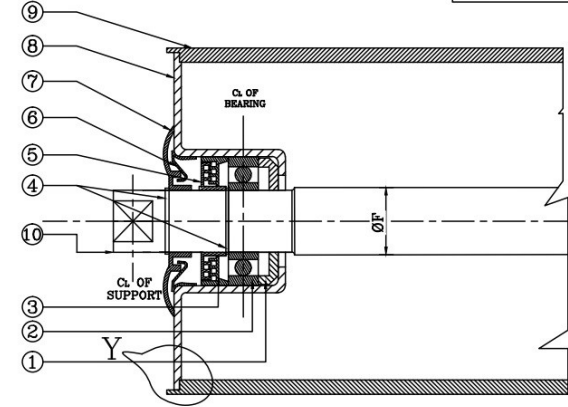
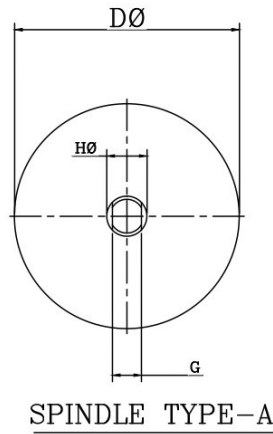
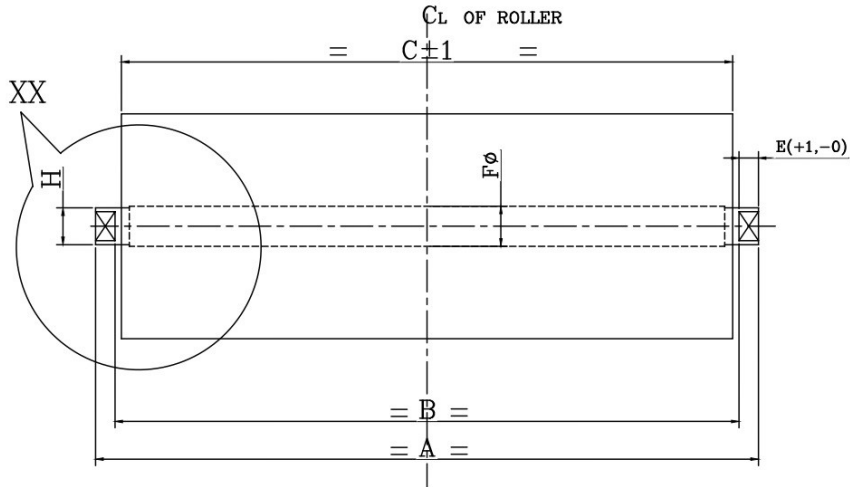

DET-XX
SPINDLE TYPE-A

SI NO	B/W	A	B	C	DØ	E	FØ	G	HØ	SHAFT DIA AT BEARING	BRG.NO.	BRG.MAKE	WT.OF ROTATING PARTS APPROX (KG)	WT.OF SINGLE ROLL APPROX (KG)	REMARKS
1	1800	702	678	670	152.4	12	30.15	22	30	30	6206-Z	SKF/FAG/NBC	14	18	CARRYING, S.A. CARRYING,

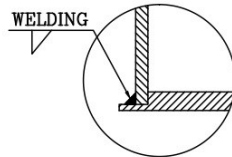

DETAIL-Y

- NOTE:-**
- ALL DIMENSIONS ARE IN MM U.O.S.
 - TUBE THICKNESS WILL BE 4.5 MM WITHOUT NEGATIVE TOLERANCE .
 - ALL IDLER TUBE MATERIAL ERW AS PER IS:9295,(YST-210)-1983.
 - BEARING LIFE IS 30000 WORKING HOURS,<B-10>.
 - BEARING SIZE 6206-Z. C3 CLEARANCE AND (MAKE-SKF/FAG/NBC) .
 - FRICITION FACTOR MAX 0.015 AS PER IS 11592-2000.
 - IDLER ARE DUST PROOF,WATER PROOF & WEATHER PROOF .
 - ALL IDLER ARE MANUFACTURE AS PER IS:8598-1987.
 - SHAFT MATERIAL EN-8/C-40/C-45 BRIGHT BAR AS PER BS:970-1983/IS:1570-1979.
 - TOTAL INDICATOR READING <TIR>ON IDLER OD,WHEN ROTATED TO CHECK RUNOUT AS PER IS:8598-1987.
 - PAINTING WILL BE AS PER CONTRACT SPECIFICATION:GID-208-ME-ECS-SA-4515-REV-2 , TESTING AND INSPECTION WILL BE DONE AS PER APPROVED QAP
 - SEALING -GREASE PACKED AND SEALED FOR LIFE LITHIUM BASE GREASED TO BE USED.
 - IDLERS ARE DROP IN TYPE & ROLLS CAN BE REMOVED WITHOUT DISMANTLING THE BRACKET FROM THE CONV. STRUCTURE.
 - ALL ROLLS ARE INTERCHANGEABLE FOR THE SAME BELT WIDTH.
 - IDLERS ARE PROVIDED WITH MULTI LABYRINTH SEALING.
 - ALL SHARP CORNERS TO BE GROUND SMOOTH.
 - ALL THE TESTING TO BE DONE AS PER IS:8598-1987 .

SI NO	QTY	DESCRIPTION	MATERIAL
10	1	SHAFT	SEE NOTE-09
09	1	TUBE	ERW-IS:9295
08	2	BEARING HOUSING	MADE OF 3.16MM AS PER IS:513 GR-DD
07	2	RAIN CAP	NYLON-6
06	2	DUST COVER/END CAP 0.6mm THK.	IS:513, CRCA-DD
05	2	OUTER LABYRINTH	NYLON-6
04	4	CIRCLIP-A30/HEAVY DUTY	IS:3075
03	2	INNER LABYRINTH	NYLON-6
02	2	SINGLE ROW DEEP GROOVE BALL BEARING	6206-Z C3 CLEARANCE
01	2	NYLON BACK SEAL	NYLON-6

SPARE ASSEMBLY

SI NO	QTY	DESCRIPTION	MATERIAL
BILL OF MATERIAL			

Painting Specification:-					
SL.NO.	TYPE	TYPE OF PREPARATION	REFERENCE STANDARD		
1	Grade of Surface Preparation	Power Tool Cleaning (Wire Wheel/ Wire brush)	SSPC-SP3	SIS-St 3	
Frame	2	Primer Coat	Light Grey Zinc Chromate as per IS: 2074/ IS 12744	No of Coats	2
				Microns	35
	3	Final Coat	Synthetic enamel paint as per IS: 2932	2	35
Frame Total DFT (microns)					140
Roller	4	Primer Coat	Light Grey Zinc Chromate as per IS: 2074/ IS 12744	No of Coats	1
				Microns	35
	5	Final Coat	Synthetic enamel paint as per IS: 2932	1	35
Roller Total DFT (microns)					50-70
6	Final Color Shade	DARK ADMIRALITY Grey-Shade No-632			

OPGC CHP-2

CLIENT:- BGR ENERGY SYSTEMS LIMITED

JOB No. : _____ TITLE : **G.A OF CARRYING ROLLER**

NAME	SIGN	DATE
DSGN DHANJEE		23.05.16
DRWN DHANJEE		23.05.16
CHKD MANAS		23.05.16
APPD MANOJ		23.05.16

PROJECTION

REV. A

SCALE - NTS SHEET - 3 of 3 PAGE - A3

CAD SOFTWARE AutoCAD

REV. NO.	DATE	DETAIL OF REVISION	DSGN.	DRWN.	CHD.	APP.
A	03.06.16	REVISED AS PER EARLIER DRG.	DHANJEE	DHANJEE	MANAS	MANOJ
O	23.05.16	FIRST SUBMISSION	DHANJEE	DHANJEE	MANAS	MANOJ

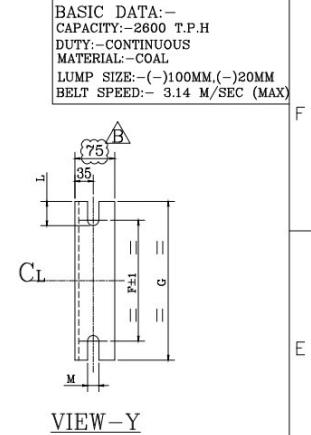
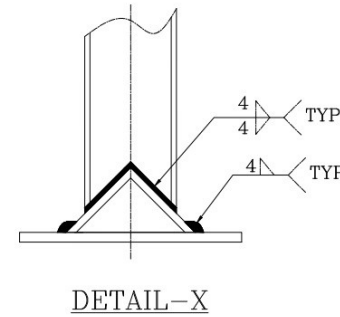
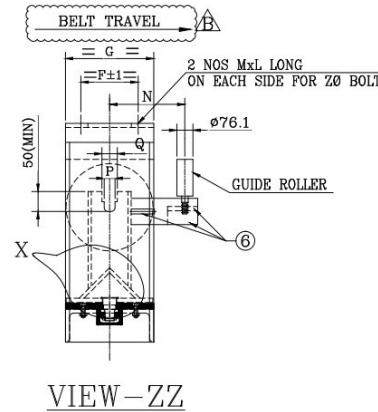
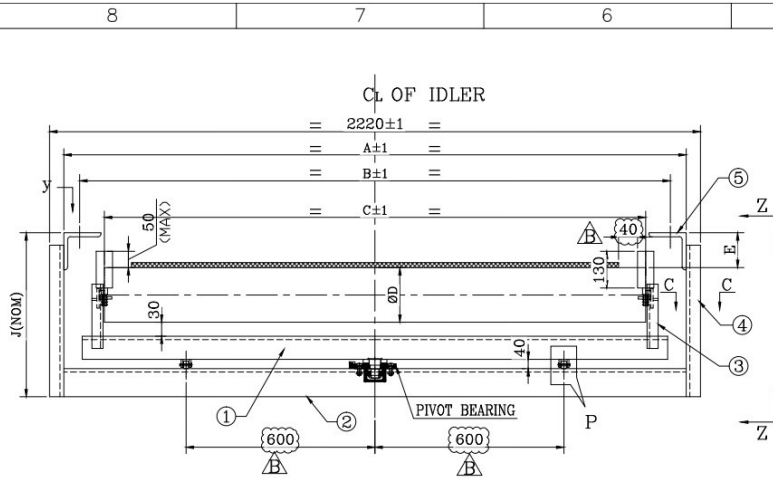

BASIC DATA:-
CAPACITY:-2600 T.P.H
DUTY:-CONTINUOUS
MATERIAL:-COAL
LUMP SIZE:-(-)100MM.(-)20MM
BELT SPEED:- 3.14 M/SEC (MAX)

SI NO	B/W	A	B	C	DØ	E ⁺³	F	G	J	P	Q	L	M	N	SHAFT DIA.	SHAFT DIA AT BEARING	BRG.NO.	BRG.MAKE	WT.OF ROTATING PARTS (KG)	ASSY.WT OF IDLER ASS(KG)	ZØ BOLT	TOTAL QTY
1	1800	2170	2100	2000	152.4	75	65	150	447	29	38	53.5	22	150	35.15	35	6207-Z	SKF/FAG/NBC	36	135	M20	394 SETS

ALL STRUCTURAL MATERIAL IS OF IS:2062,GR-A

1800	ISA-100X100X8	ISMC 150x75	ISMC 75x40	6 THK. PL.	ISA-75X75X8	8 THK. PL.
BW	BASE ANGLE(1)	BASE CHANNEL(2)	END BKT(3)	'C' TYPE PLATE(4)	BASE FOOT(5)	STIFFNER(6)

BILL OF MATERIALS

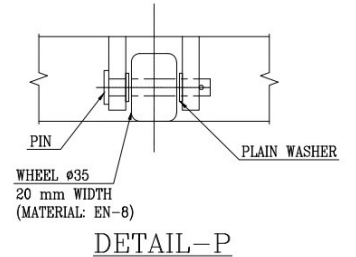

- NOTE:-**
- ALL DIMENSIONS ARE IN MM U.O.S.
 - TUBE THICKNESS WILL BE 4.5 MM WITHOUT NEGATIVE TOLERANCE.
 - ALL IDLER TUBE MATERIAL ERW AS PER IS:9295,(YST-210)-1983.
 - BEARING LIFE IS 30000 WORKING HOURS,<B-10>.
 - BEARING SIZE 6207-Z C3 CLEARANCE AND (MAKE-SKF/FAG/NBC)
 - FRICTION FACTOR MAX 0.015 AS PER IS 11592-2000.
 - IDLER ARE DUST PROOF,WATER PROOF & WEATHER PROOF.
 - ALL IDLER ARE MANUFACTURED AS PER IS:8598-1987.
 - SHAFT MATERIAL EN-8/C-40/C-45 BRIGHT BAR AS PER BS:970-1983/IS:1075-1979.
 - TOTAL INDICATOR READING <TIR>ON IDLER OD,WHEN ROTATED TO CHECK RUNOUT AS PER IS:8598-1987.
 - PAINING WILL BE AS PER CONTRACT SPECIFICATION GID-208-ME-ECS-SA-4515-REV-2, TESTING AND INSPECTION WILL BE DONE AS PER APPROVED QAP .
 - SEALING -GREASE PACKED AND SEALED FOR LIFE LITHIUM BASE GREASED TO BE USED.
 - IDLERS ARE DROP IN TYPE & ROLLS CAN BE REMOVED WITHOUT DISMANTLING THE BRACKET FROM THE CONV. STRUCTURE.
 - ALL ROLLS ARE INTERCHANGEABLE FOR THE SAME BELT WIDTH.
 - IDLERS ARE PROVIDED WITH MULTI LABYRINTH SEALING.
 - ALL FILLET WELD ARE 4 MM (MINIMUM).
 - FOR CROSS SECTION DRAWING OF ROLL ASSY. PLEASE REFER DRG. NO- AAC/BGRESL/RR/016.
 - ALL SHARP CORNERS TO BE GROUND SMOOTH.
 - ALL THE TESTING TO BE DONE AS PER IS:8598-1987 .
 - FOR PIVOT BEARING HOUSING & GUIDE ROLLER REFER DRG. NO- AAC/BGRESL/PBHGR/017.

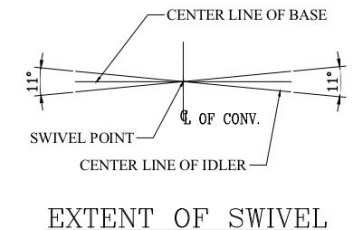
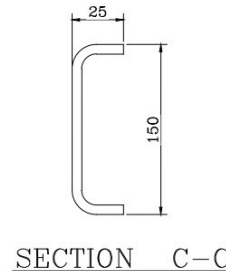

Painting Specification:-

SL.NO.	TYPE	TYPE OF PREPARATION	REFERENCE STANDARD
1	Grade of Surface Preparation	Power Tool Cleaning (Wire Wheel / Wire brush)	SSPC-SP3 SIS-SI 3
	DESCRIPTION	TYPE OF PAINT	No of Coats Microns Total DFT (microns)
2	Primer Coat	Light Grey Zinc Chromate as per IS : 2074 / IS 12744	2 35 70
3	Final Coat	Synthetic enamel paint as per IS : 2032	2 35 70
Frame Total DFT (microns) 140			
4	Primer Coat	Light Grey Zinc Chromate as per IS : 2074 / IS 12744	1 35 25-35
5	Final Coat	Synthetic enamel paint as per IS : 2032	1 35 25-35
Roller Total DFT (microns) 50-70			
6	Final Color Shade	DARK ADMIRALTY GREY- Shade No- 632	

OPGC CHP-2

CLIENT:-

JOB No. : _____ TITLE : Self Aligning Return Idler Frame

NAME	SIGN	DATE
DSGN DHANJEE		23.05.16
DRWN DHANJEE		23.05.16
CHKD MANAS		23.05.16
APPD MANOJ		23.05.16

PROJECTION

REV. B

SCALE - NTS SHEET - 2 OF 3 PAGE - A3

CAD SOFTWARE AutoCAD

REV. NO.	DATE	DETAIL OF REVISION	DSGN.	DRWN.	CHD.	APP.
B	10.06.16	REVISED AS MARKED	DHANJEE	DHANJEE	MANAS	MANOJ
A	06.06.16	REVISED AS MARKED	DHANJEE	DHANJEE	MANAS	MANOJ
O	23.05.16	FIRST SUBMISSION	DHANJEE	DHANJEE	MANAS	MANOJ

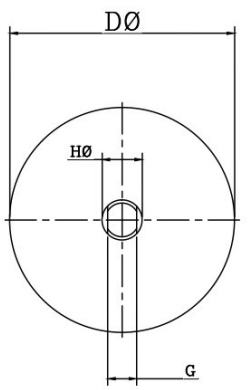
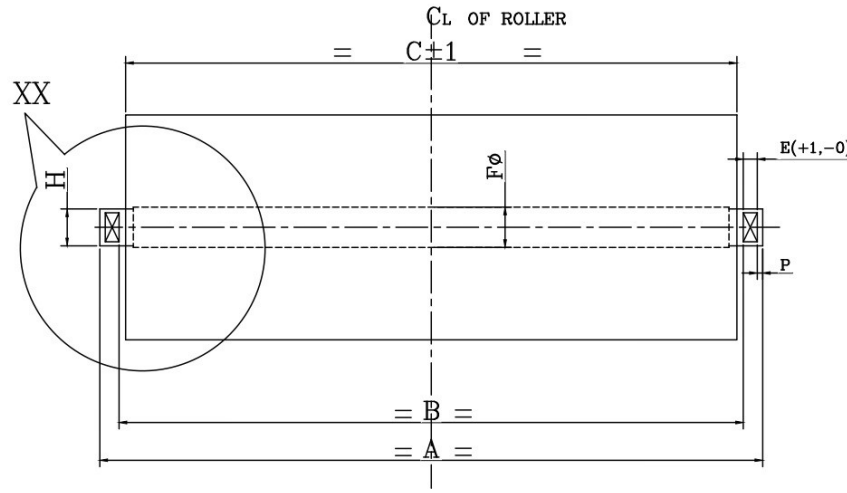

SPINDLE TYPE-A

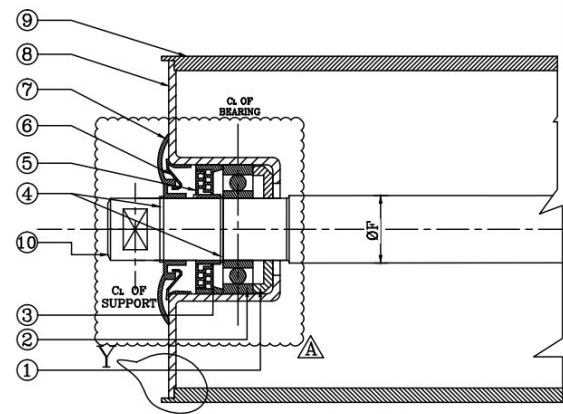

DET-XX
SPINDLE TYPE-A

BASIC DATA:-
CAPACITY:-2600 T.P.H
DUTY:-CONTINUOUS
MATERIAL:-COAL
LUMP SIZE:-(-)100MM.(-)20MM
BELT SPEED:- 3.14 M/SEC (MAX)

SI NO	B/W	A	B	C	DØ	E	FØ	G	HØ	P	SHAFT DIA AT BEARING	BRG.NO.	BRG.MAKE	WT.OF ROTATING PARTS APPROX (KG)	WT.OF SINGLE ROLL APPROX (KG)	REMARKS
1	1800	2036	2008	2000	152.4	9	35.15	28	35	5	35	6207-Z	SKF/FAG/NBC	36	51	SINGLE ROLL FLAT RETURN, S.A. RETURN

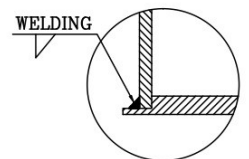

DETAIL-Y

- NOTE:-
- ALL DIMENSIONS ARE IN MM U.O.S.
 - TUBE THICKNESS WILL BE 4.5 MM WITHOUT NEGATIVE TOLERANCE .
 - ALL IDLER TUBE MATERIAL ERW AS PER IS:9295,(YST-210)-1983.
 - BEARING LIFE IS 30000 WORKING HOURS.<B-10>.
 - BEARING SIZE 6207-Z C3 CLEARANCE AND (MAKE-SKF/FAG/NBC)
 - FRICITION FACTOR MAX 0.015 AS PER IS 11592-2000.
 - IDLER ARE DUST PROOF,WATER PROOF & WEATHER PROOF .
 - ALL IDLER ARE MANUFACTURE AS PER IS:8598-1987.
 - SHAFT MATERIAL EN-8/C-40/C-45 BRIGHT BAR AS PER BS:970-1983/IS:1570-1979.
 - TOTAL INDICATOR READING <TIR>ON IDLER OD,WHEN ROTATED TO CHECK RUNOUT AS PER IS:8598-1987.
 - PAINING WILL BE AS PER CONTRACT SPECIFICATION:GID-208-ME-ECS-SA-4515-REV-2 , TESTING AND INSPECTION WILL BE DONE AS PER APPROVED QAP
 - SEALING -GREASE PACKED AND SEALED FOR LIFE LITHIUM BASE GREASED TO BE USED.
 - IDLERS ARE DROP IN TYPE & ROLLS CAN BE REMOVED WITHOUT DISMANTLING THE BRACKET FROM THE CONV. STRUCTURE.
 - ALL ROLLER ARE INTERCHANGEABLE FOR THE SAME BELT WIDTH.
 - IDLERS ARE PROVIDED WITH MULTI LABYRINTH SEALING.
 - ALL SHARP CORNERS TO BE GROUND SMOOTH.
 - ALL THE TESTING TO BE DONE AS PER IS:8598-1987 .

SI NO	QTY	DESCRIPTION	MATERIAL
10	1	SHAFT	SEE NOTE-09
09	1	TUBE	ERW-IS:9295
08	2	BEARING HOUSING	MADE OF 3.16MM AS PER IS:513 BR-3D
07	2	RAIN CAP	NYLON-6
06	2	DUST COVER/END CAP	IS:513, CRCA-DD
05	2	OUTER LABYRINTH	NYLON-6
04	4	CIRCLIP-A30/HEAVY DUTY	IS:3075
03	2	INNER LABYRINTH	NYLON-6
02	2	SINGLE ROW DEEP GROOVE BALL BEARING	SEE NOTE - 05
01	2	NYLON BACK SEAL	NYLON-6

SPARE ASSEMBLY

BILL OF MATERIAL

SL.NO.	TYPE	TYPE OF PREPARATION	REFERENCE STANDARD
1	Grade of Surface Preparation	Power Tool Cleaning (Wire Wheel / Wire brush)	SSPC-SP3
2	Primer Coat	Light Grey Zinc Chromate as per IS :2074 / IS 12744	SIS-S 3
3	Final Coat	Synthetic enamel paint as per IS :2932	
Frame Total DFT (microns) 140			
4	Primer Coat	Light Grey Zinc Chromate as per IS :2074 / IS 12744	
5	Final Coat	Synthetic enamel paint as per IS :2932	
Roller Total DFT (microns) 50-70			
6	Final Color Shade	DARK ADMIRALTY Grey- Shade No- 632	

OPGC CHP-2

CLIENT:- **BGR ENERGY SYSTEMS LIMITED**

JOB No. : _____ TITLE : **GA OF SINGLE ROLL FLAT RETURN ROLLER**

NAME	SIGN	DATE
DSGN DHANJEE		23.05.16
DRWN DHANJEE		23.05.16
CHKD MANAS		23.05.16
APPD MANOJ		23.05.16

PROJECTION

SCALE - NTS SHEET - 3 OF 3 PAGE - A3

CAD SOFTWARE AutoCAD

REV. NO.	DATE	DETAIL OF REVISION	DSGN.	DRWN.	CHD.	APP.
A	03.06.16	REVISED AS MARKED	DHANJEE	DHANJEE	MANAS	MANOJ
O	23.05.16	FIRST SUBMISSION	DHANJEE	DHANJEE	MANAS	MANOJ